

VAR	MODEL	CUST. PT. NO.	A	HP	VOLTS	SF	AMPS	HZ	RPM	CONN VOLTS	PROTECTOR	DESCRIPTION / REMARKS
001	C55JWV-2200	T14C2P4ZS	11.37	1/4	115/230	1.15	5.3/2.7	60	1725	---	NONE	48YZ, TEFC, BALL BEARING

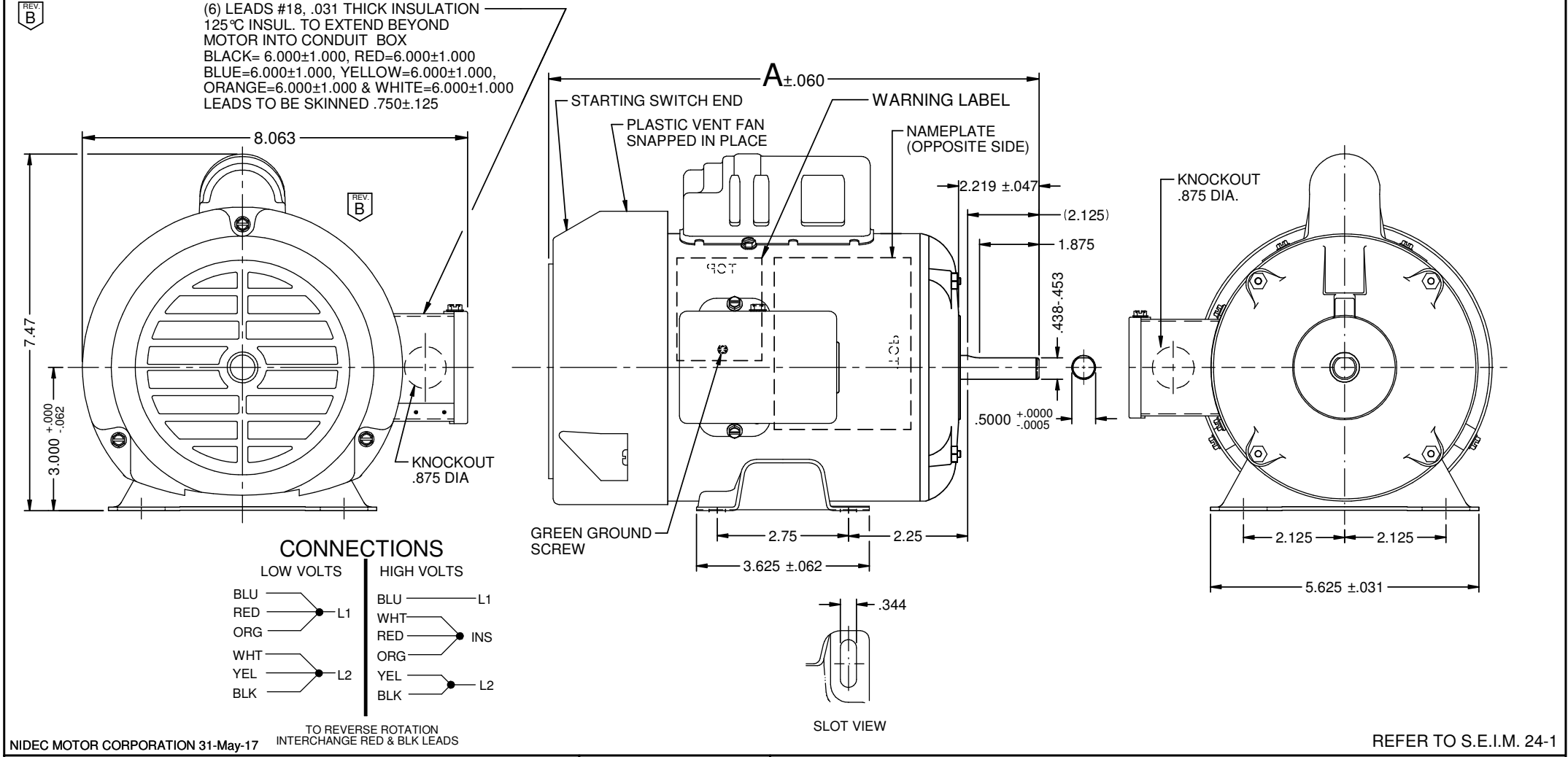

**CONNECTIONS**

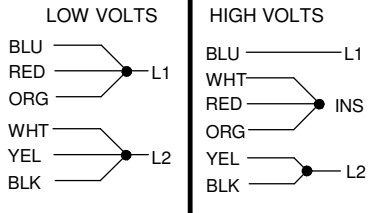

TO REVERSE ROTATION  
 INTERCHANGE RED & BLK LEADS

NIDEC MOTOR CORPORATION 31-May-17

REFER TO S.E.I.M. 24-1

<b>REVISION RECORD FOR:</b> ECO: E28783 IT WAS DELETED PROTECTOR IN ALL PAGES AND NOTE IN PAGE 1 AND 2 IT WAS UPDATED CHART IN PAGE 1 AND 2		TOLERANCES ON DIMENSIONS (UNLESS OTHERWISE SPECIFIED) INCHES .XX = ± .010 .XXX = ± .005 mm ANGLES X° = ±1°	<b>NIDEC MOTOR CORPORATION</b> INFORMATION DISCLOSED ON THIS DOCUMENT IS CONSIDERED PROPRIETARY AND SHALL NOT BE REPRODUCED OR DISCLOSED WITHOUT WRITTEN CONSENT OF NIDEC MOTOR CORPORATION		REVISION DATE: <b>31-MAY-17</b>
ISSUED BY: <b>F. GARCIA</b>	ENGINEER APPROVED: <b>C. ROESSLER</b>	TITLE <b>CUSTOMER DETAIL DRAWING</b>		CODE <b>V02</b>	ITEM NO. <b>812703</b>
				REV <b>B</b>	SHEET NUMBER <b>1 OF 4</b>
				DWG SIZE <b>B</b>	