

MODEL	REF	CUSTOMER	HP	VOLTS	AMPS	HZ	RPM	ROTATION	CATALOG NO.	DESCRIPTION / REMARKS
K55HXTLW-9491		STANDARD	1/3	208-230	2.4	60	1075/3 SPD	CCW. LEAD END REV	3786	

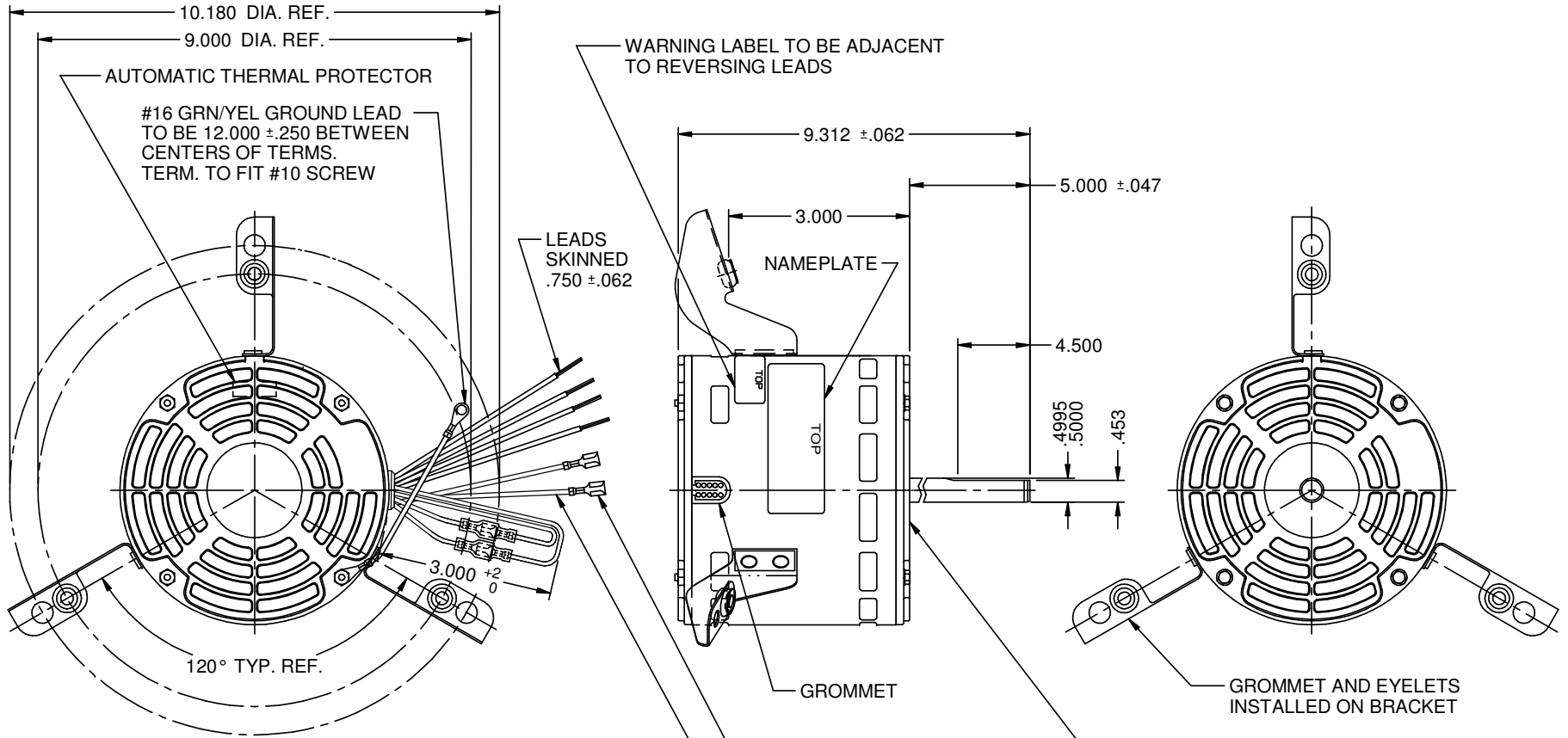

- NOTE:  
1.) OUTER BOLT CIRCLE DIA. DIM. IS FOR MANUFACTURING REFERENCE ONLY.  
2.) (4) LEADS, #18 .031 THICK INSUL. (2) YELLOW & (2) ORANGE FOR REVERSING ROTATION.

6 LEADS, #18, .031 THICK INSUL. TO EXTEND BEYOND MOTOR:  
WHT (C)= 24.000 +2 -0, BLK (1)= 24.000 +2 -0,  
BLU (2)= 24.000 +2 -0, RED (3)= 24.000 +2 -0,  
BRN= 24.000 +2 -0, BRN/WHT (//)= 24.000 +2 -0  
FIGURES TO BE PRINTED ON LEADS

(2) .250 STRAIGHT TYPE Q.C. TERMS. WITH INSUL. GRIP ON BRN LEADS ONLY

OIL SLING TO BE PLACED IN OPERATING POSITION AGAINST FACE OF BRG. CAP

NIDEC MOTOR CORPORATION 30-Oct-18

REFER TO S.E.I.M. 24-1

REVISION RECORD FOR: ECO E32712		DIMENSIONS ARE FOR REFERENCE ONLY		<b>NIDEC MOTOR CORPORATION</b> INFORMATION DISCLOSED ON THIS DOCUMENT IS CONSIDERED PROPRIETARY AND SHALL NOT BE REPRODUCED OR DISCLOSED WITHOUT WRITTEN CONSENT OF NIDEC MOTOR CORPORATION				REVISION DATE: 30-OCT-18	
DELETE ASSEMBLY INSTRUCTIONS		UNLESS TOLERANCE IS SPECIFIED						TITLE: CUSTOMER DETAIL DRAWING	CODE: V02
ISSUED BY: A.GARCIA	ENGINEER APPROVED: P.RODRIGUEZ								