

MODEL	REF	CUSTOMER	HP	VOLTS	AMPS	HZ	RPM	ROTATION	CAT. NO.	DESCRIPTION / REMARKS
K48HXSTZ-3519		STANDARD	1/4	115	2.8	60	1050/3	CCWLE REVERSIBLE	1390	

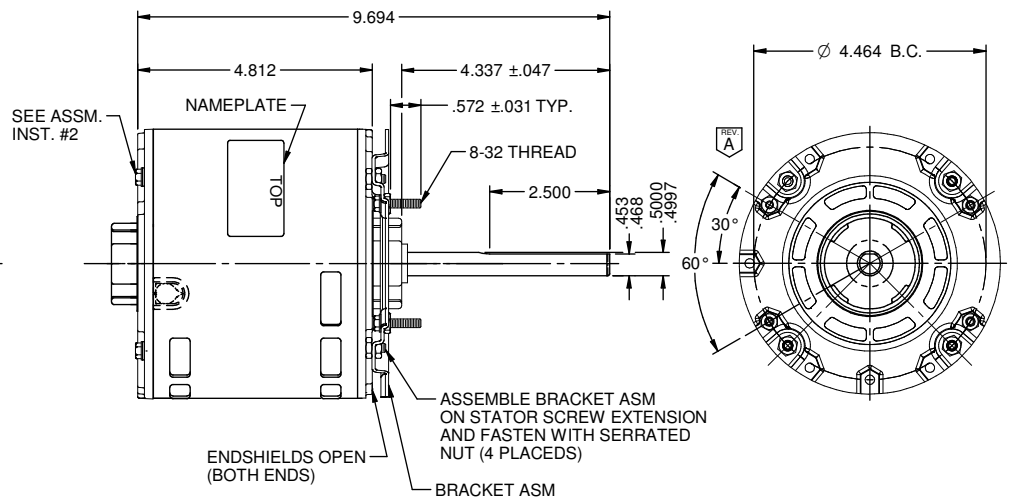
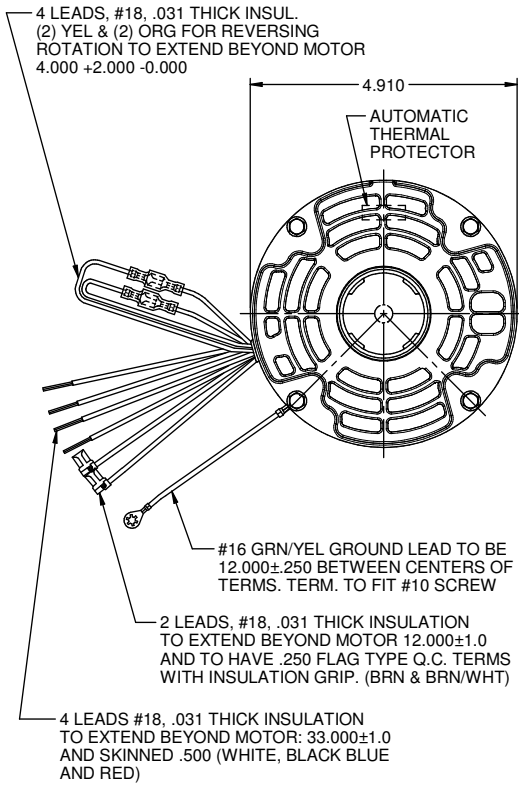

NIDEC MOTOR CORPORATION 10-Jul-18

REFER TO S.E.I.M. 24-1

REVISION RECORD FOR:	ECO E31734
CHANGED TO CORRECT VIEW OF BRACKET OLE	
ISSUED BY:	C. LUGO
ENGINEER APPROVED:	P. RODRIGUEZ

DIMENSIONS ARE FOR
REFERENCE ONLY

UNLESS TOLERANCE
IS SPECIFIED

NIDEC MOTOR CORPORATION

INFORMATION DISCLOSED ON THIS DOCUMENT IS CONSIDERED PROPRIETARY AND SHALL NOT BE
REPRODUCED OR DISCLOSED WITHOUT WRITTEN CONSENT OF NIDEC MOTOR CORPORATION

REVISION DATE:
10-JUL-18

TITLE	CODE	ITEM NO.	REV	SHEET NUMBER	DWG SIZE
CUSTOMER DETAIL DRAWING	V02	815987	A	1 OF 3	B