

MODEL	REF	CUSTOMER	HP	VOLTS	AMPS	HZ	RPM	ROTATION	CAT. NO.	DESCRIPTION / REMARKS
K48HXAFE-1312		WHOLESALE - HAC	1/4	277	1.61	60	1075/3 SPD	CCW LEAD END	1424	K48 BALL BEARING, OPEN

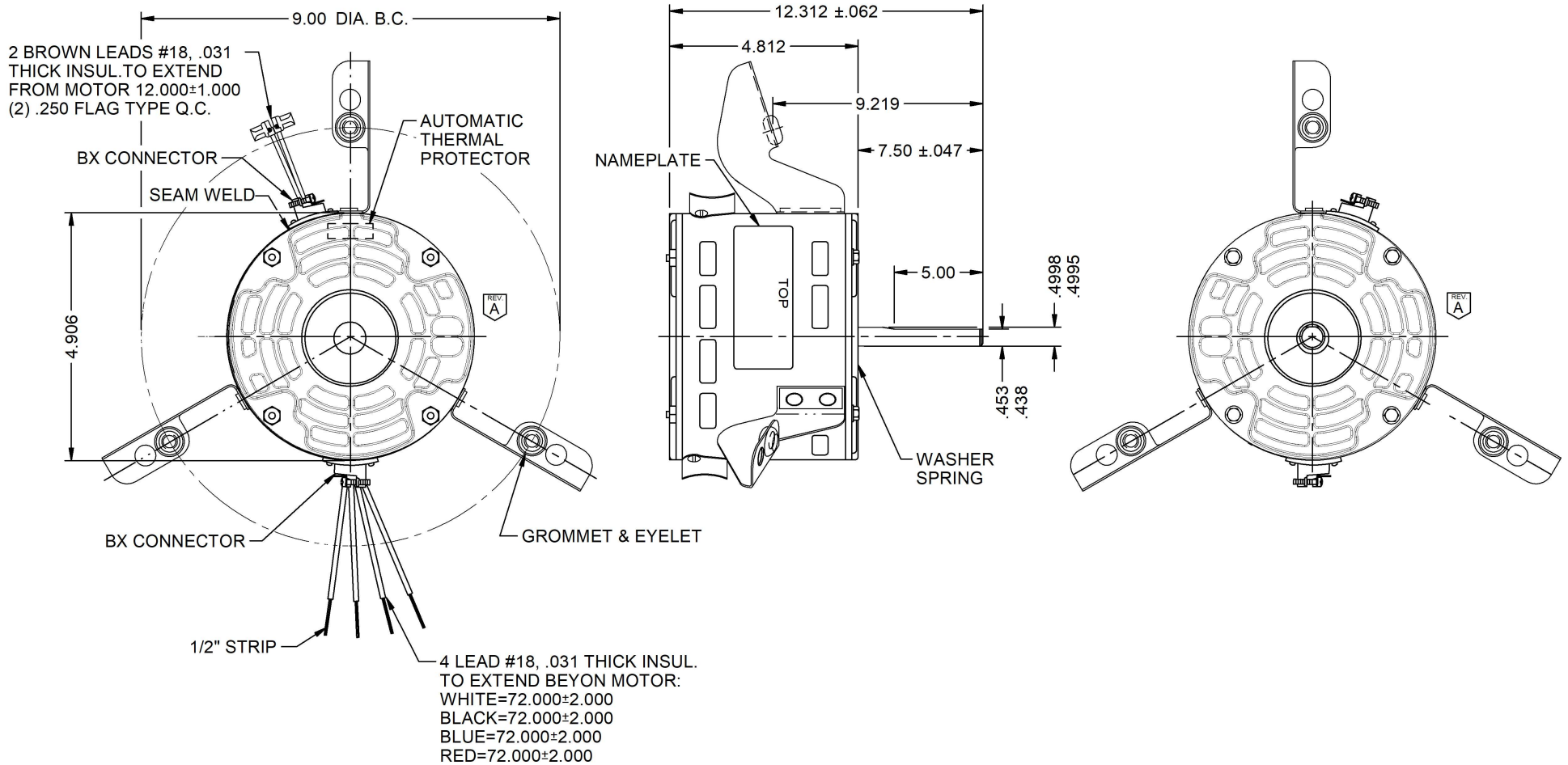

NIDEC MOTOR CORPORATION 07-Jan-20

REFER TO S.E.I.M. 24-1

REVISION RECORD FOR:	E36085
ELIMINATED VIEW OF BEARING CAP IN BOTH ENDS.	
ISSUED BY:	G. ISASSI
ENGINEER APPROVED:	B. GAITAN

DIMENSIONS ARE FOR REFERENCE ONLY

UNLESS TOLERANCE IS SPECIFIED

<b>NIDEC MOTOR CORPORATION</b>			
INFORMATION DISCLOSED ON THIS DOCUMENT IS CONSIDERED PROPRIETARY AND SHALL NOT BE REPRODUCED OR DISCLOSED WITHOUT WRITTEN CONSENT OF NIDEC MOTOR CORPORATION			
TITLE			REVISION DATE :
CUSTOMER DETAIL DRAWING			07-JAN-20
CODE	ITEM NO.	REV	SHEET NUMBER
V02	820656	A	1 OF 3
			DWG SIZE
			B