

MODEL	REF	CUSTOMER	HP	VOLTS	AMPS	HZ	RPM	ROTATION	CUSTOMER PT. NO.	DESCRIPTION / REMARKS
K55XZSCA-1006		STANDARD	3/4	208-230/460	5.0/2.5	60	1075	CCW LEAD END, REV	K5489	K55 HUB, MTD. BALL BEARING OPEN

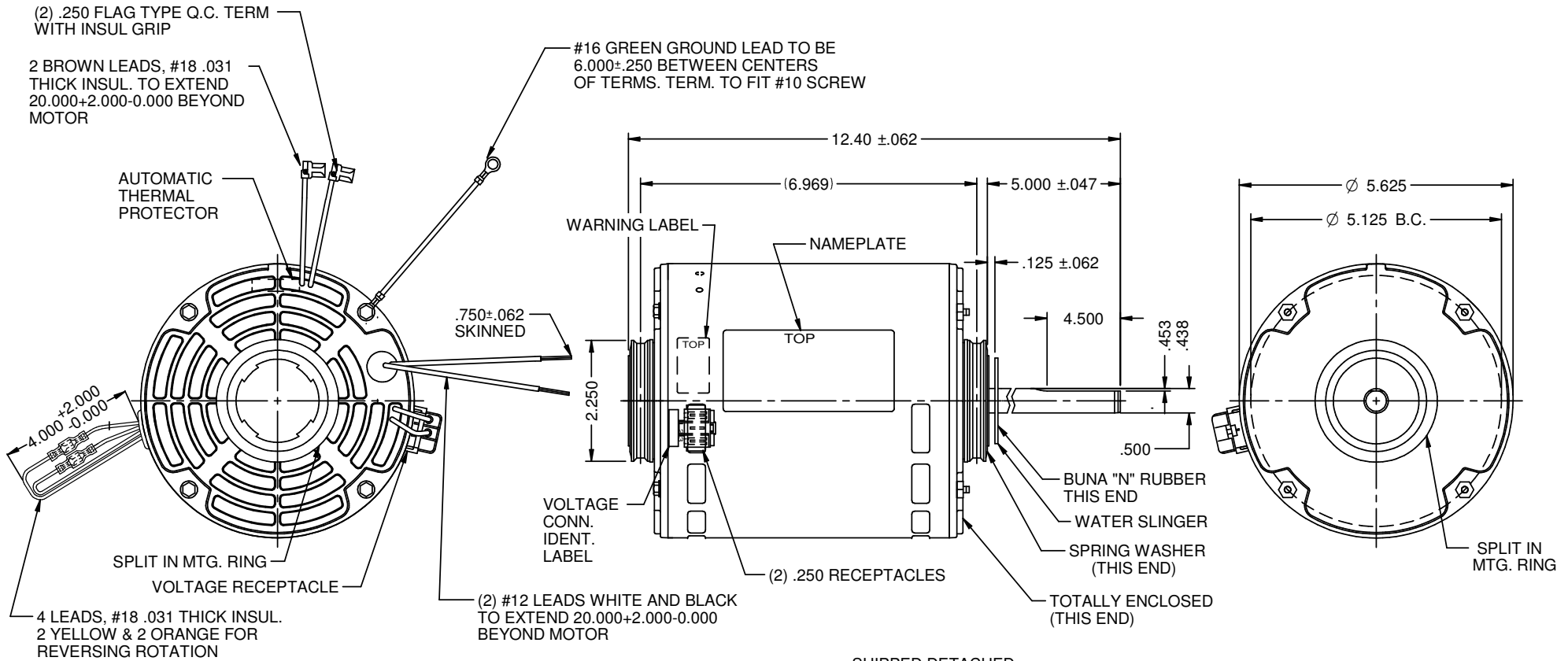

- SHIPPED DETACHED:
 (1) - CAPACITOR
 (1) - CAPACITOR CLAMP
 (1) - CAPACITOR CAP
 (2) - 8-18 SCREWS
 (1) - KEY
 (1) - BUSHING

TO REVERSE ROTATION INTERCHANGE ORANGE & YELLOW LEADS

REFER TO S.E.I.M. 24-1

NIDEC MOTOR CORPORATION 26-Sep-18

NEW DRAWING.	REVISION RECORD FOR:	ECO: E32250
ISSUED BY:	G. ISASSI	ENGINEER APPROVED:
		Z. TREVIÑO

DIMENSIONS ARE FOR REFERENCE ONLY
 UNLESS TOLERANCE IS SPECIFIED

NIDEC MOTOR CORPORATION			
INFORMATION DISCLOSED ON THIS DOCUMENT IS CONSIDERED PROPRIETARY AND SHALL NOT BE REPRODUCED OR DISCLOSED WITHOUT WRITTEN CONSENT OF NIDEC MOTOR CORPORATION			REVISION DATE:
TITLE			26-SEP-18
CUSTOMER DETAIL DRAWING	CODE	ITEM NO.	REV
V02	822856	-	SHEET NUMBER
			1 OF 3
			DWG SIZE
			B