

MODEL	REF	CUSTOMER	HP	VOLTS	AMPS	HZ	RPM	ROTATION	CUSTOMER PT. NO.	DESCRIPTION / REMARKS
K55HXSWW-7987		STANDARD	3/4	115	12.1	60	1075/4 SPD	CCW LEAD END REV	3340	K55 S/A BRG. HUB MTD, OPEN

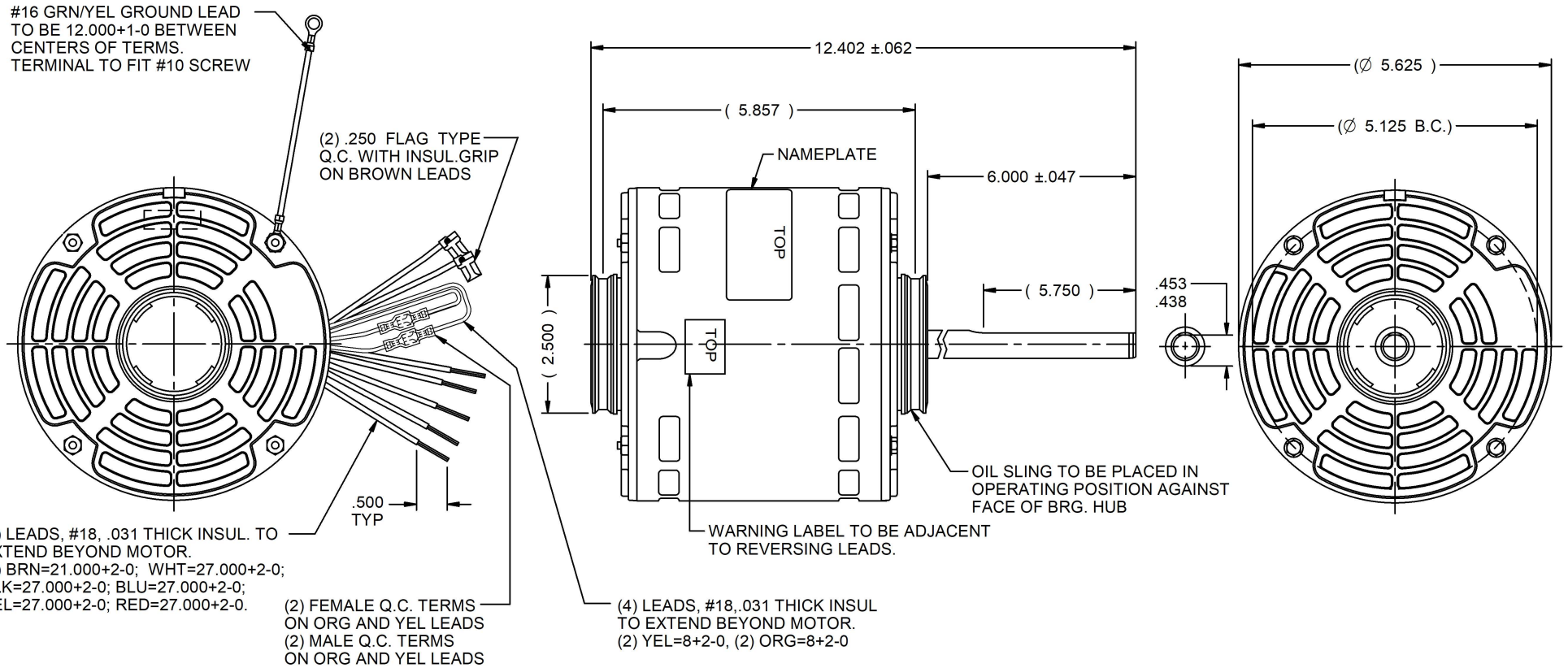

NIDEC MOTOR CORPORATION 15-Nov-18

REFER TO S.E.I.M. 24-1

REVISION RECORD FOR: ECO: E32643

NEW DRAWING.

DIMENSIONS ARE FOR REFERENCE ONLY

NIDEC MOTOR CORPORATION

INFORMATION DISCLOSED ON THIS DOCUMENT IS CONSIDERED PROPRIETARY AND SHALL NOT BE REPRODUCED OR DISCLOSED WITHOUT WRITTEN CONSENT OF NIDEC MOTOR CORPORATION

REVISION DATE: 15-NOV-18

ISSUED BY: G. ISASSI

ENGINEER APPROVED: Z. TREVIÑO

UNLESS TOLERANCE IS SPECIFIED

TITLE CUSTOMER DETAIL DRAWING

CODE V02 ITEM NO. 823554

REV - SHEET NUMBER 1 OF 3 DWG SIZE B