

MODEL	REF	CUSTOMER	HP	VOLTS	AMPS	HZ	RPM	ROTATION	CAT. #	DESCRIPTION / REMARKS
K55HXWRM-0126	A31014	WHOLESALE - HAC	1/2	460	1.4	60/50	1115	CCW LEAD END REV.	3738PEP	K55, TOTALLY ENCLOSED, STUD MOUNTING, BALL BEARING

#16 GREEN/YELLOW GROUND LEAD TO BE 12.000 ±.250 BETWEEN CENTER OF TERMS. TERM. TO FIT #10 SCREW

USE WITH 10 MFD 370 VAC CAPACITOR

(4) LEADS #18, .031 THICK INSUL. TO EXTEND BEYOND MOTOR: BLACK= 48.000 +2-0, WHITE= 48.000 +2-0, BROWN= 48.000 +2-0 & BRN/WHT STRIPE= 48.000 +2-0

NOTE:
(4) SCREWS INCLUDED IN CARTON

(2) .250 STRAIGHT TYPE Q.C. TERMS. ON BROWN LEADS

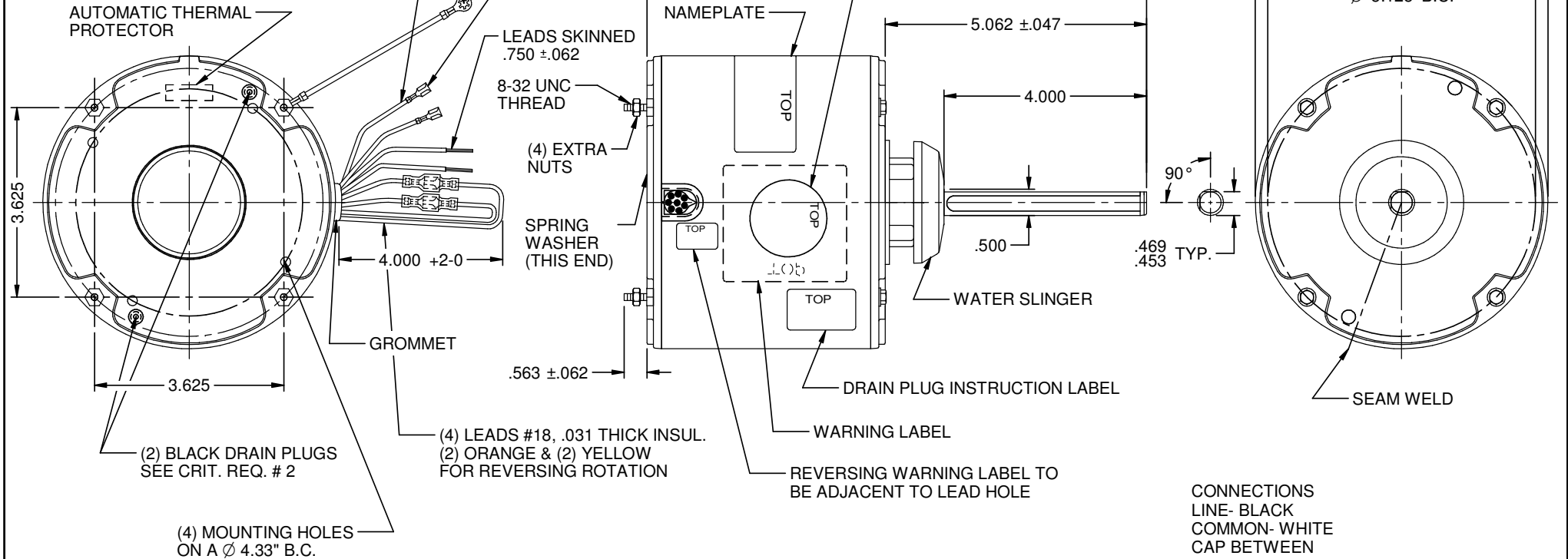

ROTATION IS CCW VIEWING LEAD END WITH ORG. TO ORG. & YEL. TO YEL. TO REVERSE ROTATION INTERCHANGE ORG. & YEL. LEADS.

CONNECTIONS
LINE- BLACK
COMMON- WHITE
CAP BETWEEN
BRN & BRN/WHT LEADS

NIDEC MOTOR CORPORATION 21-Nov-18

REFER TO S.E.I.M. 24-1

REVISION RECORD FOR: ECO E32044	
DRAWING WAS CREATED	
ISSUED BY: G. TREVIÑO	ENGINEER APPROVED: J. RICE

DIMENSIONS ARE FOR REFERENCE ONLY

UNLESS TOLERANCE IS SPECIFIED

NIDEC MOTOR CORPORATION

INFORMATION DISCLOSED ON THIS DOCUMENT IS CONSIDERED PROPRIETARY AND SHALL NOT BE REPRODUCED OR DISCLOSED WITHOUT WRITTEN CONSENT OF NIDEC MOTOR CORPORATION

REVISION DATE: 22-NOV-18

TITLE: CUSTOMER DETAIL DRAWING		CODE: V02	ITEM NO.: 823563	REV: --	SHEET NUMBER: 1 OF 3	DWG SIZE: B
--------------------------------	--	-----------	------------------	---------	----------------------	-------------