

MODEL	REF	CUSTOMER	HP	VOLTS	AMPS	HZ	RPM	ROTATION	CUSTOMER PT. NO.	DESCRIPTION / REMARKS
K55HXHPB-9534		STANDARD	3/4	277	4.1	60	1075/3 SPD	CCW LEAD END REV	5847	K55 HUB MOUNT BALL BRG OPEN

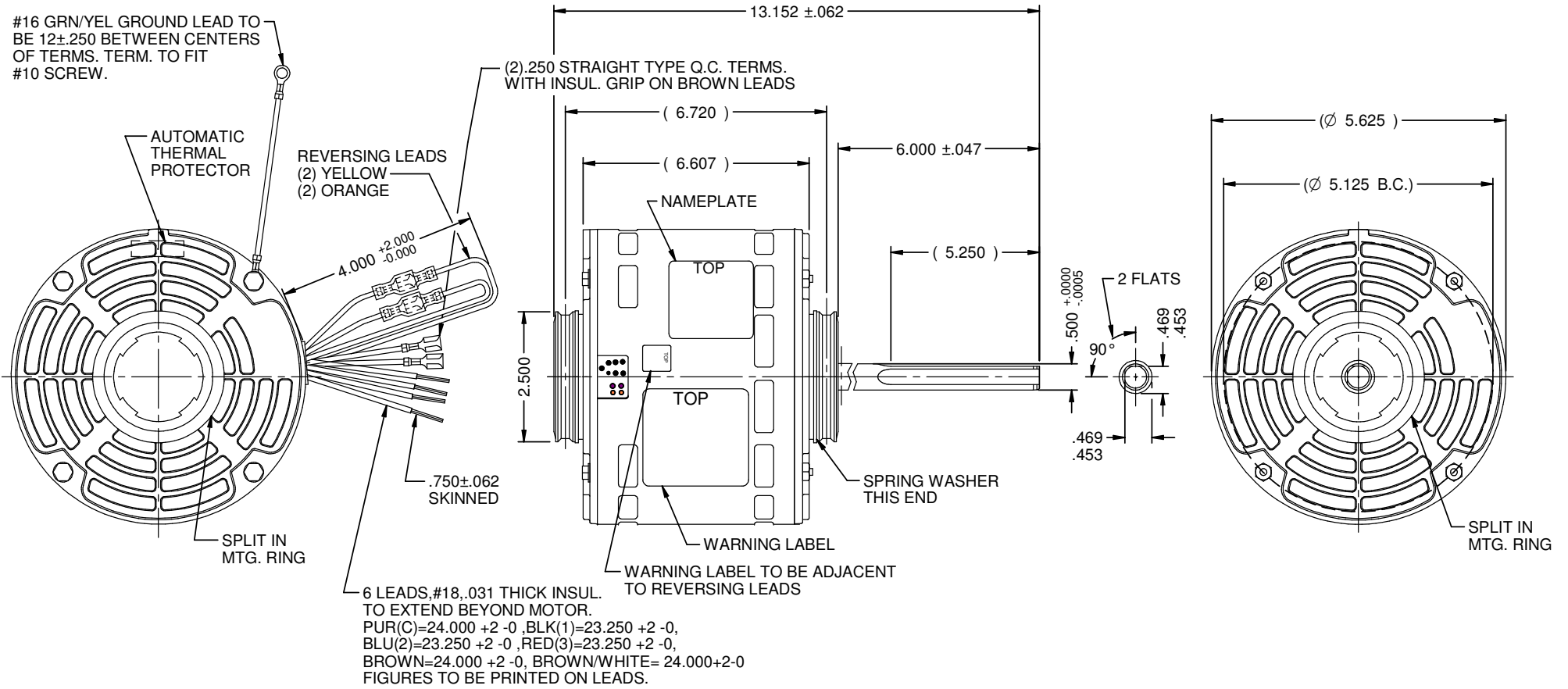

NIDEC MOTOR CORPORATION 08-Jan-19

REFER TO S.E.I.M. 24-1

REVISION RECORD FOR: ECO: E32641		DIMENSIONS ARE FOR REFERENCE ONLY	NIDEC MOTOR CORPORATION INFORMATION DISCLOSED ON THIS DOCUMENT IS CONSIDERED PROPRIETARY AND SHALL NOT BE REPRODUCED OR DISCLOSED WITHOUT WRITTEN CONSENT OF NIDEC MOTOR CORPORATION				REVISION DATE: 07-DEC-18	
NEW DRAWING.							TITLE: CUSTOMER DETAIL DRAWING	
ISSUED BY: G. ISASSI	ENGINEER APPROVED: Z. TREVIÑO	UNLESS TOLERANCE IS SPECIFIED	SOLIDEDGE					

V02_NMCB (MAR-2014)