

MODEL	REF	CUSTOMER	CUSTOMER PN	HP	VOLTS	AMPS	HZ	RPM	ROTATION	DESCRIPTION / REMARKS
K55HXSAN-1138		STANDARD	3847	1/3	230	2.2	60	1075	CCW LE REV.	KA55 STUD OR RES. MTD. SELF ALIGN BRG. OPEN

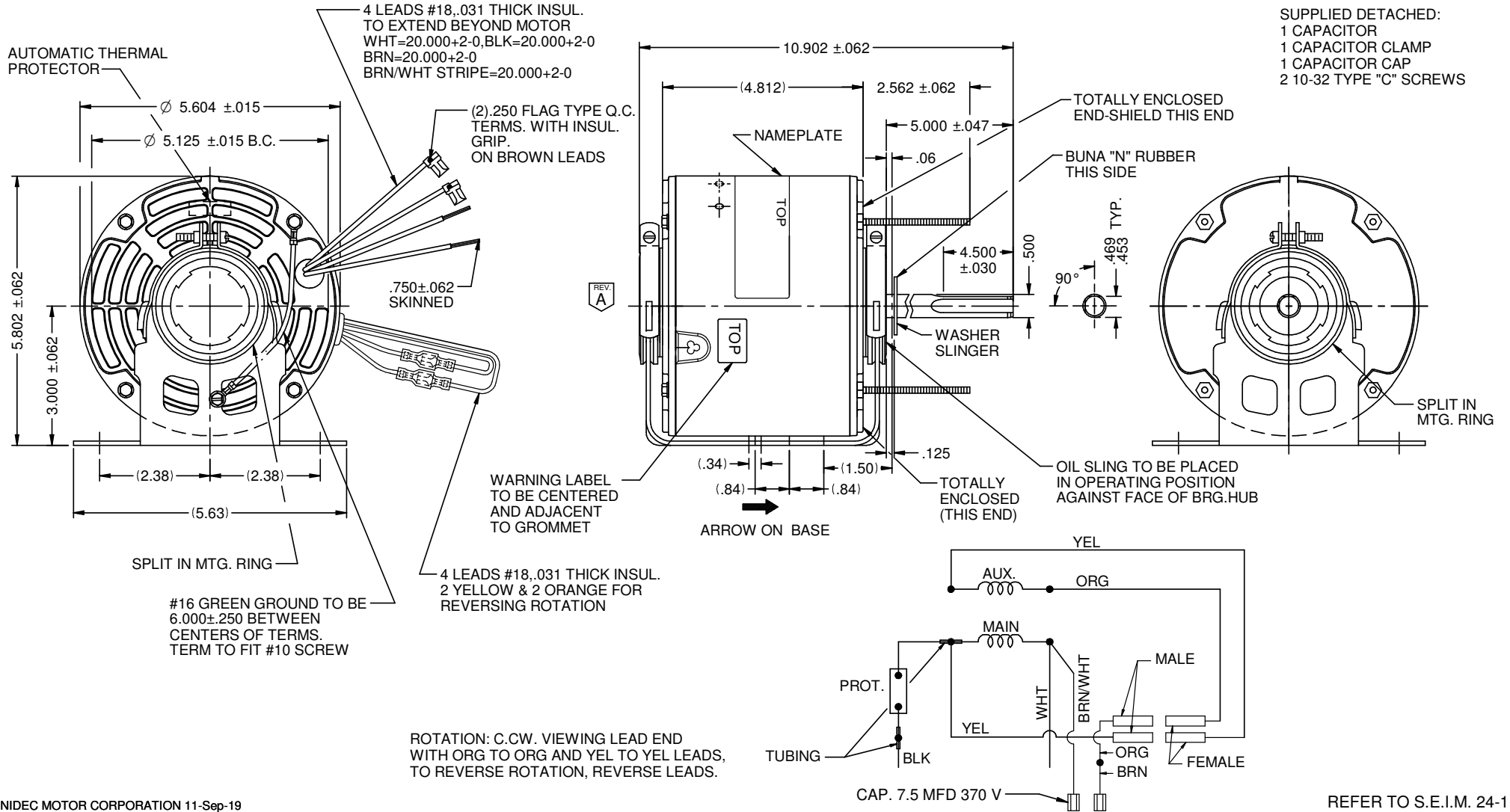

NIDEC MOTOR CORPORATION 11-Sep-19

REVISION RECORD FOR:	E35283
THE RING DIAMETER VALUE WAS REMOVED	
ISSUED BY:	E. MARTINEZ
ENGINEER APPROVED:	D. TEJEDA

DIMENSIONS ARE FOR REFERENCE ONLY
UNLESS TOLERANCE IS SPECIFIED

NIDEC MOTOR CORPORATION

INFORMATION DISCLOSED ON THIS DOCUMENT IS CONSIDERED PROPRIETARY AND SHALL NOT BE REPRODUCED OR DISCLOSED WITHOUT WRITTEN CONSENT OF NIDEC MOTOR CORPORATION

REVISION DATE: 11-SEP-19

TITLE	CODE	ITEM NO.	REV	SHEET NUMBER	DWG SIZE
CUSTOMER DETAIL DRAWING	V02	825041	A	1 OF 3	B