

MODEL	REF	CUSTOMER	CFM	VOLTS	AMPS	HZ	RPM	ROTATION	CUST. PT. NO	DESCRIPTION / REMARKS
M035TAW0115013B		WHOLESALE-HAC	270	115/230	0.9/60	60	1550	CW OSE	EC5470FP	

NOTES:

- 1.) FAN ROTATION: CW OSE
- 2.) FIVE BLADES PITCH ARE 72 DEGREES
- 3.) THE MATERIAL OF IMPELLER IS MADE FROM HOT-DIP ZINC-COATED STEEL SHEETS AND THICKNESS IS 1mm.

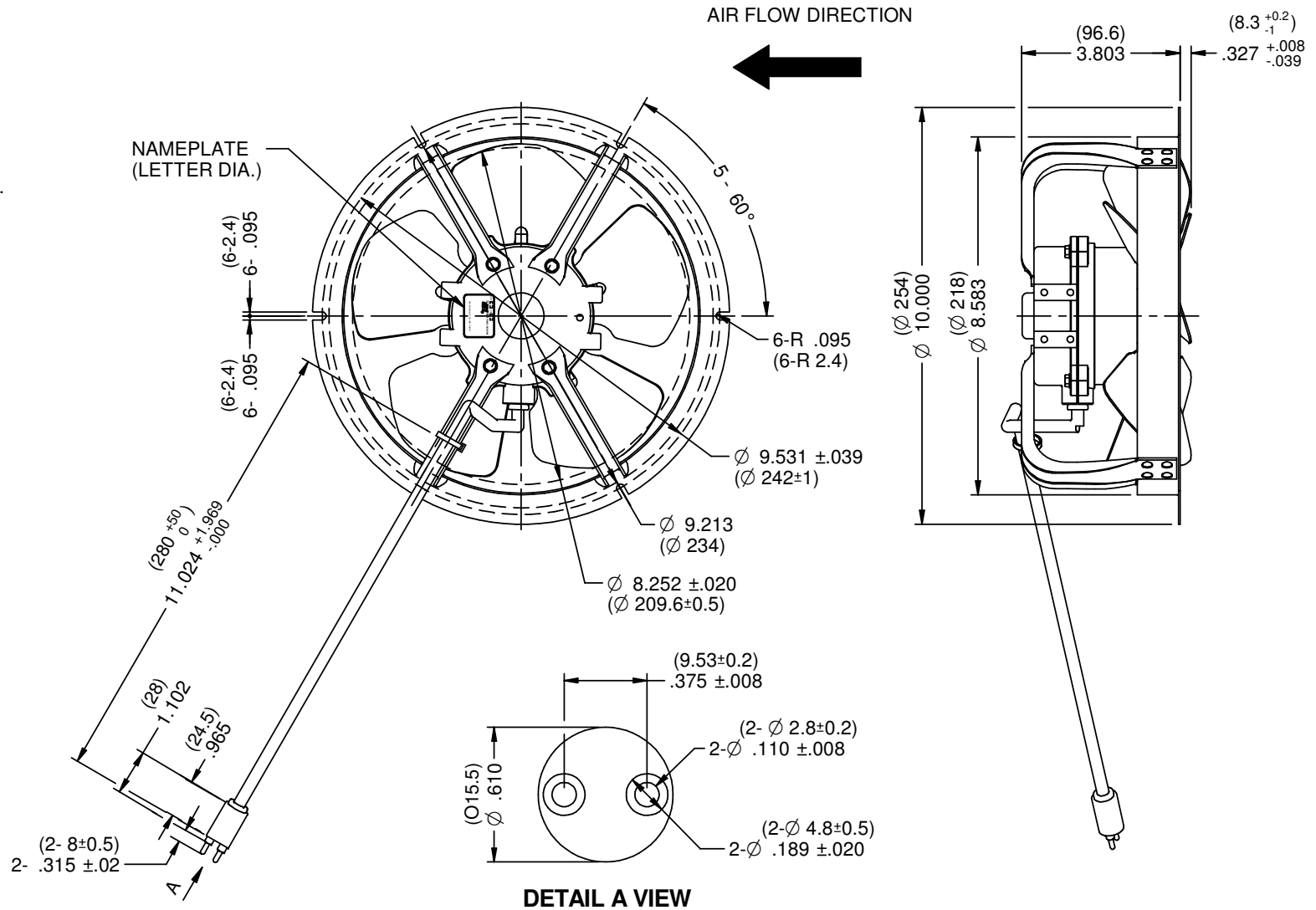

EC5470FP
 NIDEC SERVO CORPORATION
 AC115V-AC230V 1550RPM
 0.09-0.60 Arms CW OSE
 -40°C~55°C AMB CLASS A
 FP8S20UF-902 60Hz
 IP67
 AO TP
 E58417
 MADE IN CHINA

DATE [] CODE []

NIDEC MOTOR CORPORATION 08-Jul-19

REFER TO S.E.I.M. 24-1

REVISION RECORD FOR:		DIMENSIONS ARE FOR REFERENCE ONLY		NIDEC MOTOR CORPORATION			
CREATED NEW DRAWING		UNLESS TOLERANCE IS SPECIFIED		INFORMATION DISCLOSED ON THIS DOCUMENT IS CONSIDERED PROPRIETARY AND SHALL NOT BE REPRODUCED OR DISCLOSED WITHOUT WRITTEN CONSENT OF NIDEC MOTOR CORPORATION			
ECO: E34809				TITLE		REVISION DATE:	
				CUSTOMER DETAIL DRAWING		08-JUL-19	
ISSUED BY: F. GARCIA		ENGINEER APPROVED: Z. TREVIÑO		CODE	ITEM NO.	REV	SHEET NUMBER
				V02	827973	-	1 OF 3
							DWG SIZE
							B