

MODEL	REF	CUSTOMER	HP	VOLTS	AMPS	HZ	RPM	ROTATION	CUSTOMER PART	DESCRIPTION / REMARKS
K55HXTNK-9629		STANDARD	1	460	2.5	60	1080	C.C.W. LEAD END	CAT8055	K55 STRAP MTD. BALL BEARING, OPEN

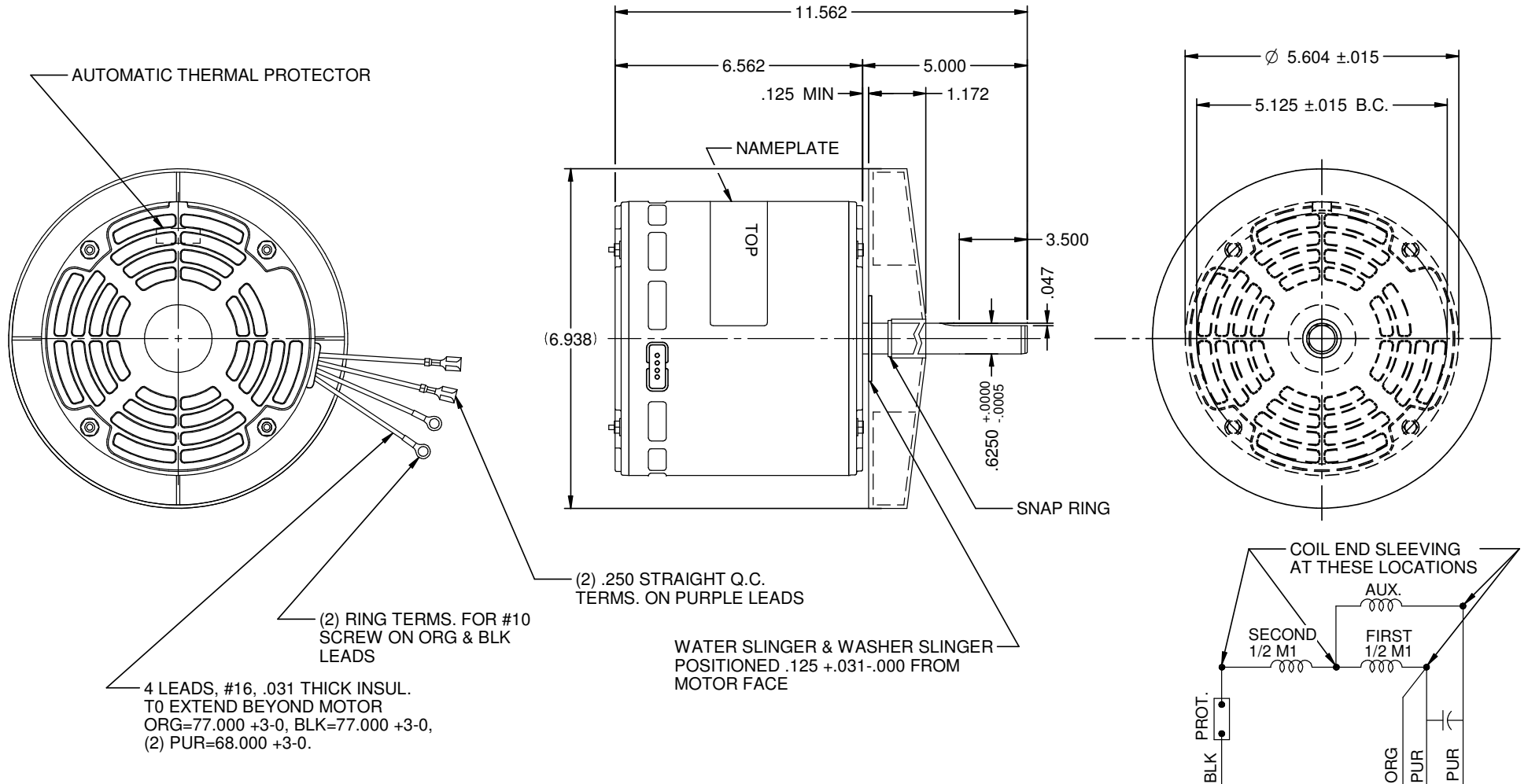

NIDEC MOTOR CORPORATION 08-Feb-21

REFER TO S.E.I.M. 24-1

NEW DRAWING CREATED	REVISION RECORD FOR: E39102
ISSUED BY: D. VALLE	ENGINEER APPROVED: G. MEDINA

DIMENSIONS ARE FOR REFERENCE ONLY  
 UNLESS TOLERANCE IS SPECIFIED

<b>NIDEC MOTOR CORPORATION</b>			
INFORMATION DISCLOSED ON THIS DOCUMENT IS CONSIDERED PROPRIETARY AND SHALL NOT BE REPRODUCED OR DISCLOSED WITHOUT WRITTEN CONSENT OF NIDEC MOTOR CORPORATION			
TITLE		CODE	ITEM NO.
CUSTOMER DETAIL DRAWING		V02	836352
REV	SHEET NUMBER	DWG SIZE	REVISION DATE
--	1 OF 3	B	08-FEB-21