

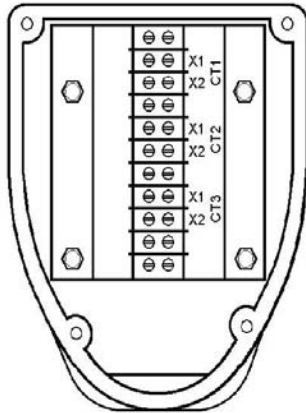

987241

Motor Wiring Diagram

Single Voltage, Delta Connected, With Current Transformers,
Lightning Arrestors & Surge Capacitors



- 1.) Attached incoming power leads to the Lightning Arrestor Terminals.
- 2.) Current Transformer leads are terminated in an Accessory Outlet Box mounted to the Main Outlet Box.

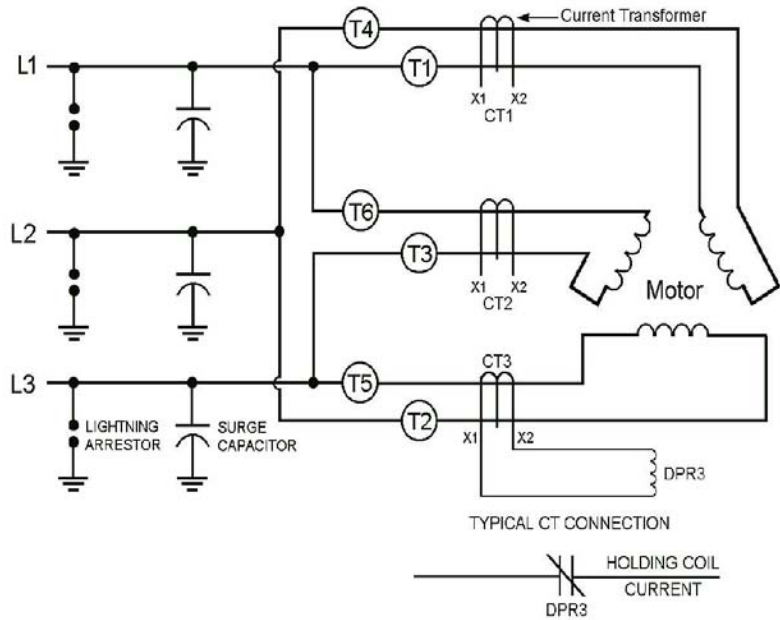

Delta Connected, Single Winding

INSTRUCTIONS

CONNECTIONS - EACH LEAD MAY CONSIST OF ONE OR MORE CABLES: L1 - T1 & T6, L2 - T2 & T4, L3 - T3 & T5
FOR CURRENT TRANSFORMERS (IF PRESENT)
LEADS 1 & 4 THROUGH CT1
LEADS 3 & 6 THROUGH CT2
LEADS 2 & 5 THROUGH CT3

MADE IN U.S.A. 359282

To reverse direction of rotation, interchange leads L1 & L2.

Each lead may have one or more cables comprising that lead. In such case, each cable will be marked with the appropriate lead number.