

200350 and 200355 Accelerometers

Bently Nevada* Asset Condition Monitoring

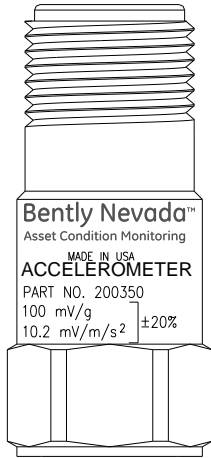

Description

The 200350 and 200355 Accelerometers are general purpose, case-mounted seismic transducers designed for use with Trendmaster* Pro Constant Current Direct Input Card 149811-02 and the Seismic Direct Input Card 164746-01.

The 200350 and 200355 Accelerometers are contained within a hermetically sealed, stainless steel case. The design provides an extremely rugged transducer, well suited for harsh industrial environments. Each transducer's top mounted, 2-pin connector (MIL-C-5015) allows for easy installation and removal of the interconnecting signal cable. A 1/4-28 threaded hole on the bottom of the casing accommodates multiple mounting options.

The 200350 and 200355 Accelerometers contain a piezoelectric sensing device, which generates charge when subjected to vibration. This charge is then converted electronically to a differential voltage signal, which is proportional to the acceleration that is parallel to the sensitive axis of the transducer.



Application Alert

If housing measurements are being made for overall protection of the machine, consider the usefulness of the measurement for each application. Most common machine malfunctions (imbalance, misalignment, etc.) originate at the rotor and cause an increase (or at least a change) in rotor vibration. For housing measurements alone to be effective for overall machine protection, a significant amount of rotor vibration must be faithfully transmitted to the bearing housing or machine casing, or more specifically, to the mounting location of the transducer.

In addition, exercise care in the physical installation of the transducer. Improper installation can result in a degradation of the transducer's performance and/or the generation of signals that do not represent actual machine vibration. Upon request, we can provide engineering services to determine the suitability of housing measurements for the machine in question and/or to provide installation



imagination at work

Specifications and Ordering Information
Part Number 164804-01
Rev. K

Specifications

Parameters are specified from +20 to +30 °C (+68 to +86 °F) and 100 Hz unless otherwise indicated.



Application Alert

Operation outside the specified limits will result in false readings or loss of machine monitoring.

Electrical

	200350	200355
Sensitivity	100 mV/g ±20% (10.2 mV/m/s ² ±20%)	100 mV/g ±5% (10.2 mV/m/s ² ±5%)
Frequency Range (±3 dB)	30-600,000 cpm (0.5-10,000 Hz)	12-600,000 cpm (0.2-10,000 Hz)
Measurement Range	± 50 g	
Transverse Sensitivity	≤ 7%	≤ 5%
Amplitude Linearity	± 1%	
Mounted Resonant Frequency	1500 kcpm (25 kHz)	1250 kcpm (20.8 kHz)
Broadband Electrical Noise (1-10kHz)	350 µg (3,434 µm/s ²)	50 µg (491 µm/s ²)
Output Bias Voltage	8 to 12 VDC	
Excitation Voltage	18 to 28 VDC	
Constant Current Excitation	2 to 20 mA	
Settling Time (within 1% of bias)	≤ 2.0 sec	≤ 5.0 sec
Output Impedance	< 150 ohms	< 100 ohms
Discharge Time Constant	≥ 0.3 sec	≥ 0.8 sec
Electrical Isolation (Case)	> 10 ⁸ ohms	

Environmental

Operating Temperature Range	-65 to +250 °F (-54 to +121 °C)
Shock Survivability	5,000 g pk
Relative Humidity	100% relative, condensing, non-submerged
Enclosure Rating	IP68

Physical

	200350	200355
Hex Size	11/16" (18 mm)	7/8" (22mm)
Height	1.65" (42.4 mm)	2.06" (52.3 mm)
Weight	1.8 oz (51 grams)	3.3 oz (94 grams)
Mounting Thread	1/4-28 Female	
Mounting Torque (Maximum)	2 to 5 ft-lb (2.7 to 6.8 N-m)	
Sensing Element	Ceramic	
Sensing Geometry	Shear	
Housing Material	Stainless Steel	
Sealing	Welded Hermetic	
Electrical Connector	2-Pin Mil-C-5015	
Electrical Connection Position	Top	

Hazardous Area Approvals

For a detailed listing of country and product specific approvals, refer to the Approvals Quick Reference Guide, document 108M1756, at www.GEmeasurement.com.

200350 Accelerometer

CSA/NRTL/C (Approval Option 01)	
Intrinsically Safe	Ex ia IIC T4 Class I, Division 1, Groups A, B, C and D
	AEx ia IIC T4 Class I, Division 1, Groups A, B, C and D T4 @ -54 °C ≤ Ta ≤ +121 °C (-65.2 °F ≤ Ta ≤ 249.8 °F) per drawing 175825
Intrinsically Safe and Non-Incendive	Ex nL IIC T4 Class I, Division 2, Groups A, B, C and D
	AEx nA T4 Class I, Division 2, Groups A, B, C and D T4 @ -54 °C ≤ Ta ≤ +121 °C (-65.2 °F ≤ Ta ≤ +249.8 °F) per drawing 175825

ATEX/IECEx (Approval Option 01)



II 1 G Ex ia IIC T4 Ga
II 3 G Ex nA IIC T4 Gc

T4 @ -54 °C ≤ Ta ≤ +121 °C
(-65.2 °F ≤ Ta ≤ +249.8 °F)

200355 Accelerometer

The 200355 accelerometer does not have hazardous area approvals at this time.

Compliance and Certifications

Electromagnetic Compatibility (EMC)	Standards EN 61326-1:2013
	Directives EMC Directive 2014/30/EU

Accessories

200350 and 200355 Accelerometer Manual

168303-01

Trendmaster* Pro System Manual

162411

Trendmaster DSM Datasheet

149831-01

Trendmaster DSM Manual

149823-01

Mounting Studs

Dimensional diagrams of all available mounting studs are shown in Figure 8.

¼-28 Mounting Stud

164373

M6x1 Mounting Stud

164372

M8X1.25 Mounting Stud

167559

Adhesive Mounting Kits

Adhesive studs are sold in kits containing two threaded studs and two mounting pads. Also in the kit is a packet of acrylic adhesive and materials to mix its two components. A scouring pad and alcohol wipe are provided for preparing the mounting surface.

Temperature Range: -67 to +250 °F (-55 to 121 °C)
Cure Time: 24 hours



Application Alert

Use of adhesive will attenuate high frequency components that may be present.

¼-28 Adhesive Mounting Kit

167563-10

M6x1 Adhesive Mounting Kit

167563-11

M8X1.25 Adhesive Mounting Kit

167563-12

Magnetic Base Kit

The magnetic base has a pull of 35 lbf and it is suitable for placement on both curved surfaces and flat surfaces. The magnet comes supplied with a ¼-28 mounting stud. A dimensional diagram of the magnetic base is shown in Figure 9.

Magnetic Base w/ Mounting Stud

286244

Cables

The Splash proof cable is not recommended for the model 200350 accelerometer.

The standard cables are 22 AWG 2-conductor twisted shielded pairs with 2-socket moisture-resistant female connector at one end, terminal lugs at the other end. Cable length is optional and comes in increments of 1 ft between the stated maximum and minimum lengths.

Splash Proof Cable

CB2W100 – AXXX

A: Length

015 15 ft

032 32 ft

064 64 ft

112 112 ft

125 125 ft

150 150 ft

200 200 ft

250 250 ft

Standard Cable, No Armor

9571 – AXX

A: Length

02 Minimum length, 2 ft

99 Maximum length, 99 ft

xx Desired length in ft

The following are standard lengths

Feet	Metres (approx.)
6	1.8
8	2.4
10	3.0
12	3.6
15	4.5
17	5.0
20	6.0
25	7.6
30	9.0
33	10.0
50	15.2
99	30.0

NOTE: Non-standard/custom lengths can also be ordered at additional cost

**Standard Cable,
Armored**

84661 – AXX

- A:** Length
03 Minimum length, 3 ft
99 Maximum length, 99 ft
xx Desired length in ft

The following are standard lengths	
Feet	Metres (approx.)
6	1.8
8	2.4
10	3.0
12	3.6
15	4.5
17	5.0
20	6.0
25	7.6
30	9.0
33	10.0
50	15.2
99	30.0

NOTE: Non-standard/custom lengths can also be ordered at additional cost

200355 Accelerometer

200355 – AXX – BXX – CXX

- A: Mounting Stud**
- 00** ¼-28 SS w/ Brass tip, 0.5"
 - 01** ¼-28 to M6 x 1.00 BeCu
 - 02** ¼-28 to M8 x 1.25 BeCu
 - 09** No mounting stud
 - 10** ¼-28 Adhesive Stud Mount
 - 11** M6x1 Adhesive Stud Mount
 - 12** M8x1.25 Adhesive Stud Mount
 - 13** Magnetic Base Kit
- B: Tolerance**
- 00** 100 mV/g ± 5% (10.2 mV/m/s² ±5%)
- C: Approvals**
- 00** No approvals

Ordering Information

For a detailed listing of country and product specific approvals, refer to the Approvals Quick Reference Guide, document 108M1756, at www.GEmeasurement.com.

200350 Accelerometer

200350 – AXX – BXX – CXX

- A: Mounting Stud**
- 00** ¼-28 SS w/ Brass tip, 0.5"
 - 01** ¼-28 to M6 x 1.00 BeCu
 - 02** ¼-28 to M8 x 1.25 BeCu
 - 09** No mounting stud
 - 10** ¼-28 Adhesive Stud Mount
 - 11** M6x1 Adhesive Stud Mount
 - 12** M8x1.25 Adhesive Stud Mount
 - 13** Magnetic Base Kit
- B: Tolerance**
- 00** 100 mV/g ± 20% (10.2 mV/m/s² ±20%)
- C: Approvals**
- 00** No approvals
 - 01** CSA, ATEX, IECEx

Graphs and Figures

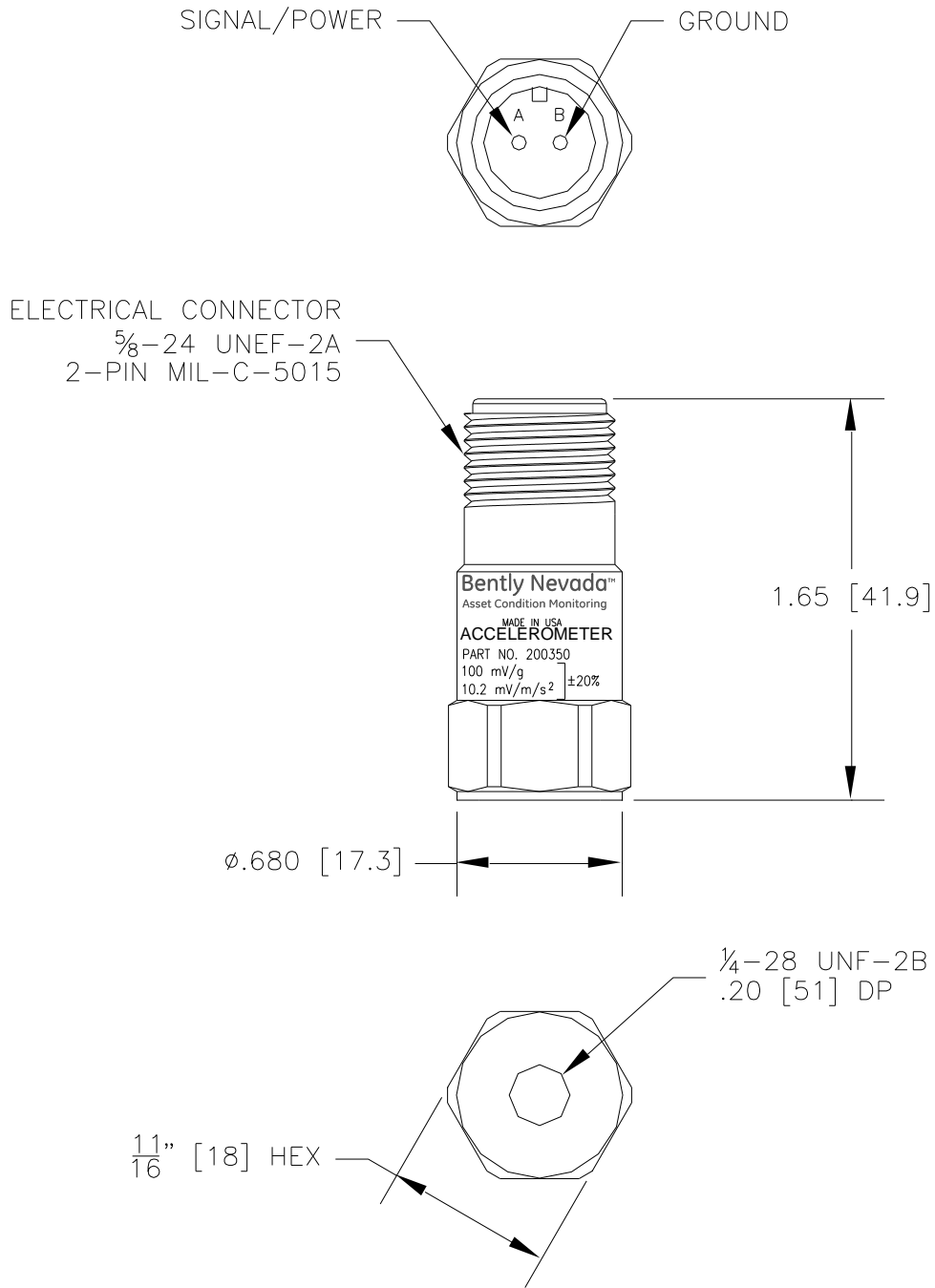

DIMENSIONS UNITS: in [mm]

Figure 1. 200350 Accelerometer Dimensional Drawing

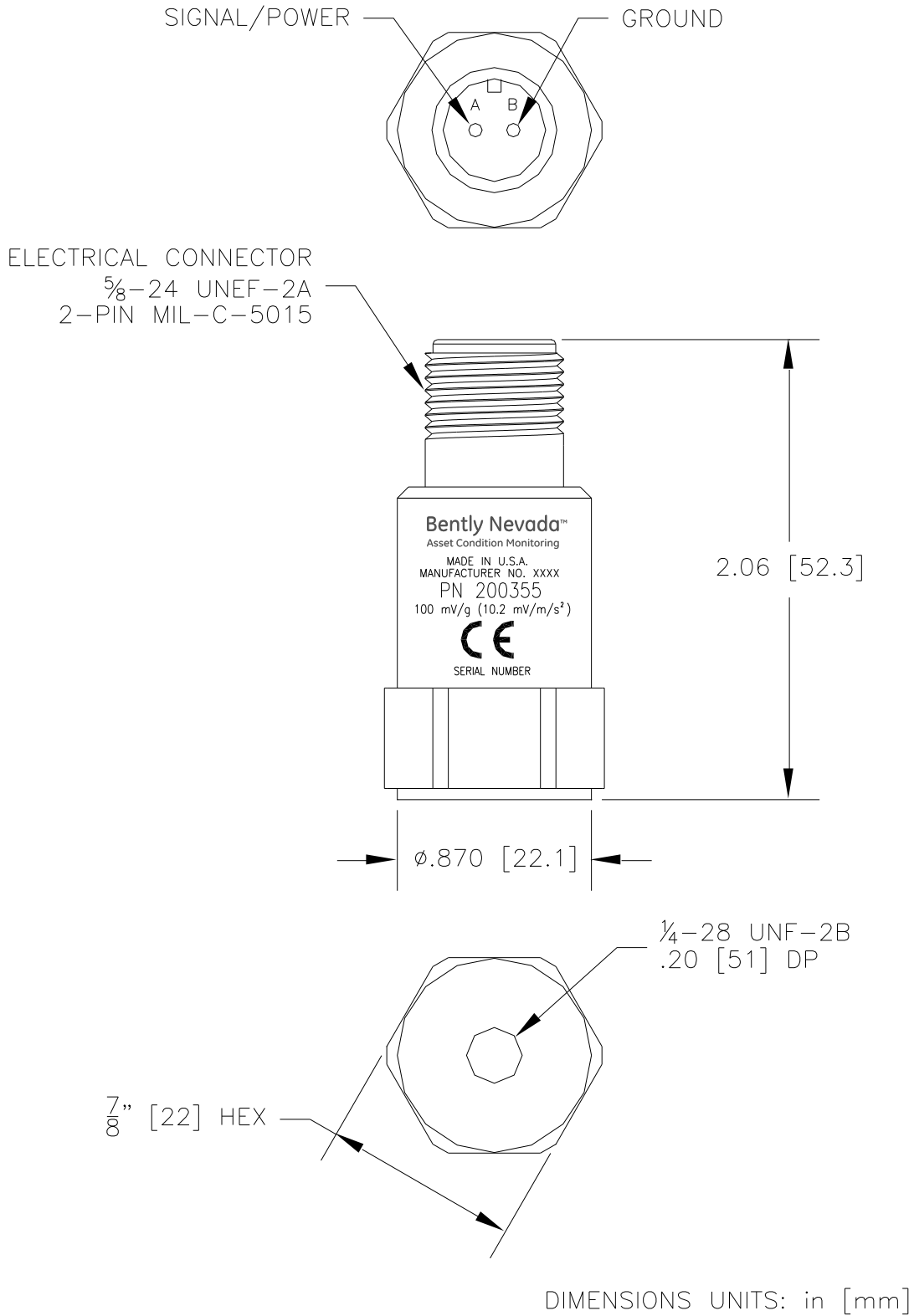

Figure 2. 200355 Accelerometer Dimensional Drawing

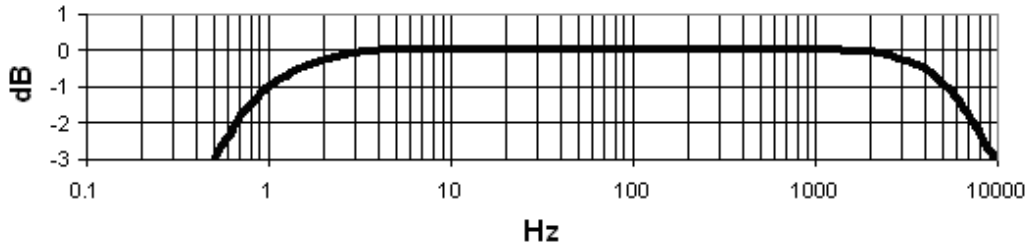

Figure 3. 200350 Accelerometer Frequency Response

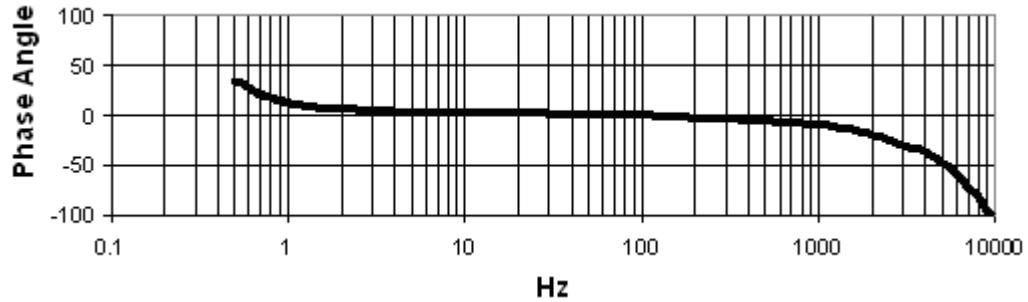

Figure 4. 200350 Accelerometer Phase

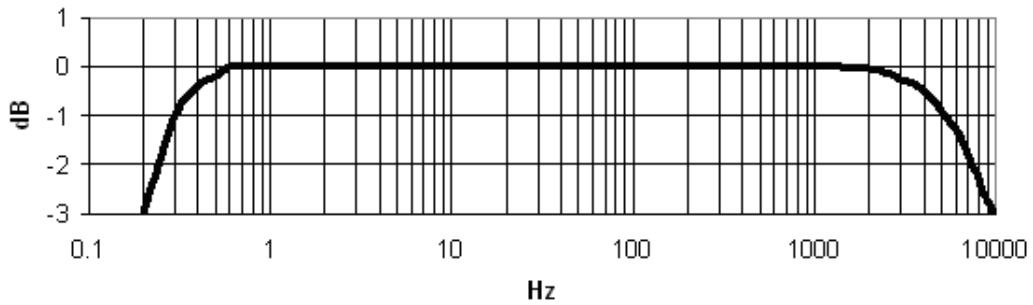

Figure 5. 200355 Accelerometer Frequency Response

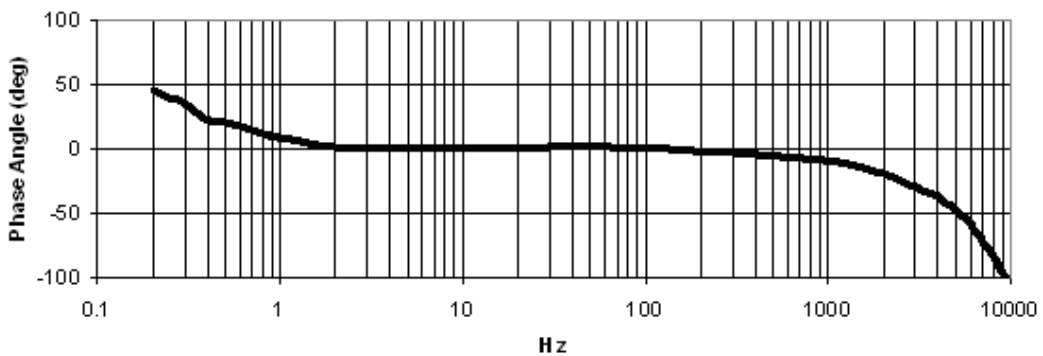

Figure 6. 200355 Accelerometer Phase

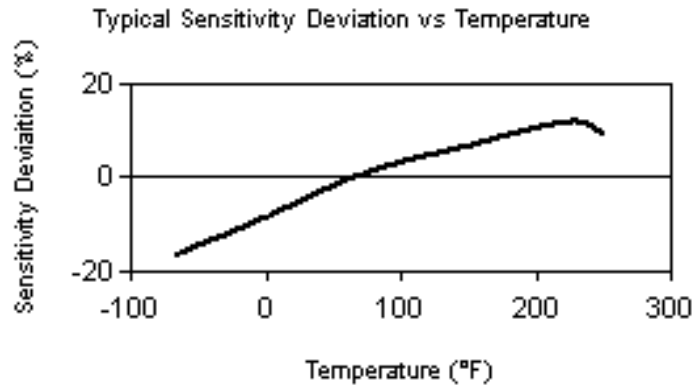

Figure 7. Temperature Sensitivity Curve

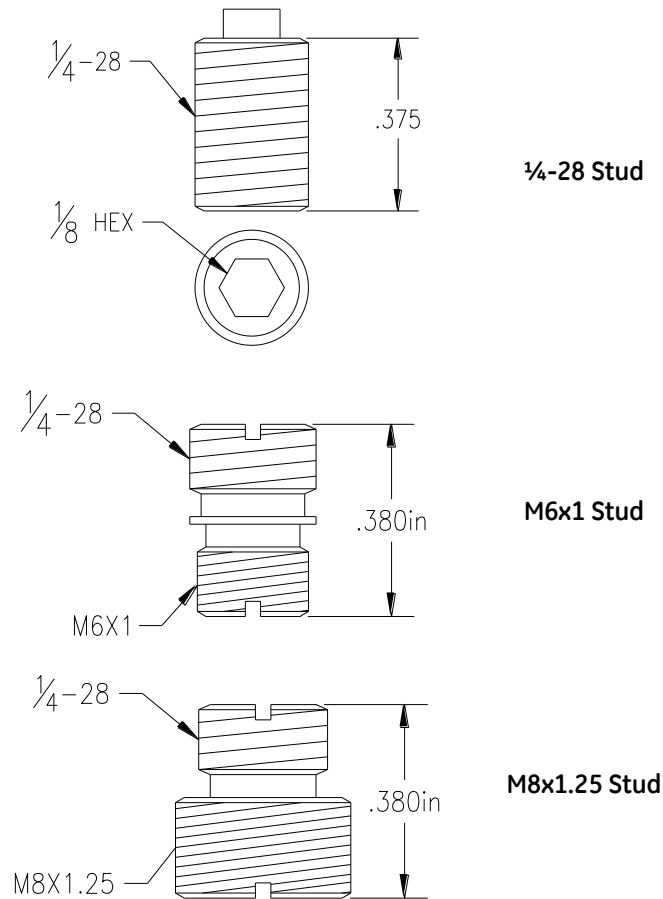

Figure 8. Mounting Stud Dimensional Drawings

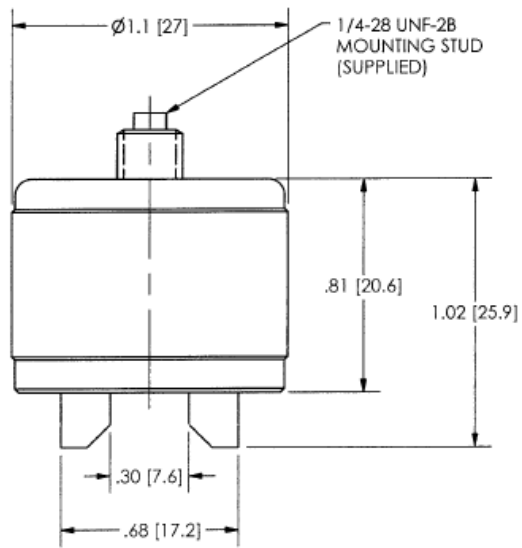

Figure 9. Magnetic Base Dimensional Drawing

* Denotes a trademark of Bently Nevada, Inc., a wholly owned subsidiary of General Electric Company.

The information contained in this document is subject to change without notice.

© 2003-2016 Bently Nevada, Inc. All rights reserved.

Printed in USA. Uncontrolled when transmitted electronically.

1631 Bently Parkway South, Minden, Nevada USA 89423

Phone: 775.782.3611 Fax: 775.215.2873

www.GEmeasurement.com