

EFFECTIVE:  
17-AUG-12

# HORIZONTAL MOTORS

ODP - CLOSE COUPLED PUMP  
FRAME: A254JP  
BASIC TYPE: D1

PRINT:  
07-2479

SUPERSEDES:  
04-APR-11

SHEET:  
1 OF 1

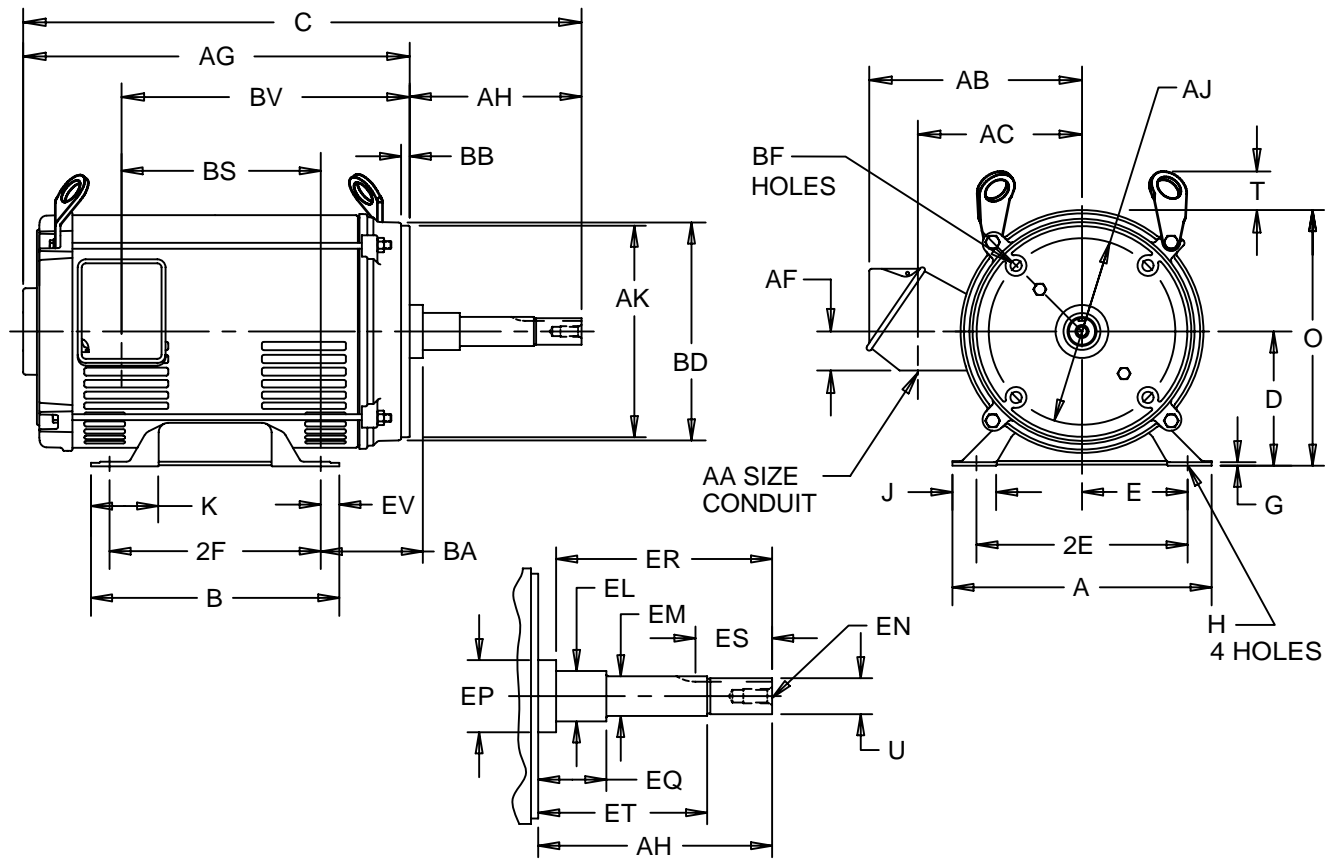

ALL DIMENSIONS ARE IN INCHES AND MILLIMETERS

UNITS	A	B	C	D -.06	E	2E ±.03	2F ±.03	G	H +.05	J	K	O	P <sup>2</sup>	T	U -.0005
IN	11.25	9.50	25.00	6.25	5.00	10.00	8.25	.19	.53	1.44	1.38	11.00	9.44	1.19	1.2495
MM	286	241	635	159	127	254	210	5	13	37	35	279	240	30	31.737

UNITS	AA	AB	AC	AF	AG	AH ±.031	AJ	AK -.003	BA	BB ±.031	BD MAX	BF <sup>3</sup>
IN		9.19	6.78	1.81	16.88	8.125	7.250	8.500	4.75	.281	10.00	
MM	1.25	233	172	46	429	206.38	184.15	215.90	121	7.14	254	1/2-13 X .75

UNITS	BS	BV	EL -.002	EM -.0005	EN <sup>3</sup>	EP MIN	EQ ±.015	ER MIN	ES MIN	ET ±.015	EV	SQ KEY
IN	6.88	11.88	1.750	1.3750		1.75	2.375	8.13	2.53	5.875	.63	.250
MM	175	302	44.45	34.925	1/2-13 X 1.00	45	60.33	206	64	149.23	16	6.35

- 1: ALL ROUGH DIMENSIONS MAY VARY BY .25" DUE TO CASTING AND/OR FABRICATION VARIATIONS.
- 2: LARGEST MOTOR WIDTH.
- 3: TAP SIZE AND BOLT PENETRATION ALLOWANCE.
- 4: ALL TAPPED HOLES ARE UNIFIED NATIONAL COARSE, RIGHT HAND THREAD.
- 5: CONDUIT BOX MAY BE LOCATED ON EITHER SIDE AND CONDUIT OPENING MAY BE LOCATED IN STEPS OF 90 DEGREES REGARDLESS OF LOCATION. STANDARD AS SHOWN WITH CONDUIT OPENING DOWN.
- 6: TOLERANCES SHOWN ARE IN INCHES ONLY.
- 7: FRAME REFERENCE: 10.25/254

TOLERANCES	
FACE RUNOUT	.004 T.I.R.
PERMISSIBLE ECCENTRICITY OF MOUNTING RABBET	.004 T.I.R.
PERMISSIBLE SHAFT RUNOUT	.002 T.I.R.

07-2479/C

**Nidec Motor Corporation**  
St. Louis, Missouri

INFORMATION DISCLOSED ON THIS DOCUMENT IS CONSIDERED PROPRIETARY AND SHALL NOT BE REPRODUCED OR DISCLOSED WITHOUT WRITTEN CONSENT OF NIDEC MOTOR CORPORATION



ISSUED BY  
**R. KING**  
APPROVED BY  
**J. O'BRIEN**

IHP\_DP\_NMCA (MAR-2011) SOLIDEDGE