

EFFECTIVE:
21-NOV-13

SUPERSEDES:
11-AUG-09

DIMENSION PRINT
UNIMOUNT WITH "C" BRACKET
FRAME: 182-184 TCH
BASIC TYPE: UT

PRINT:
07-2871

SHEET:
1 OF 1

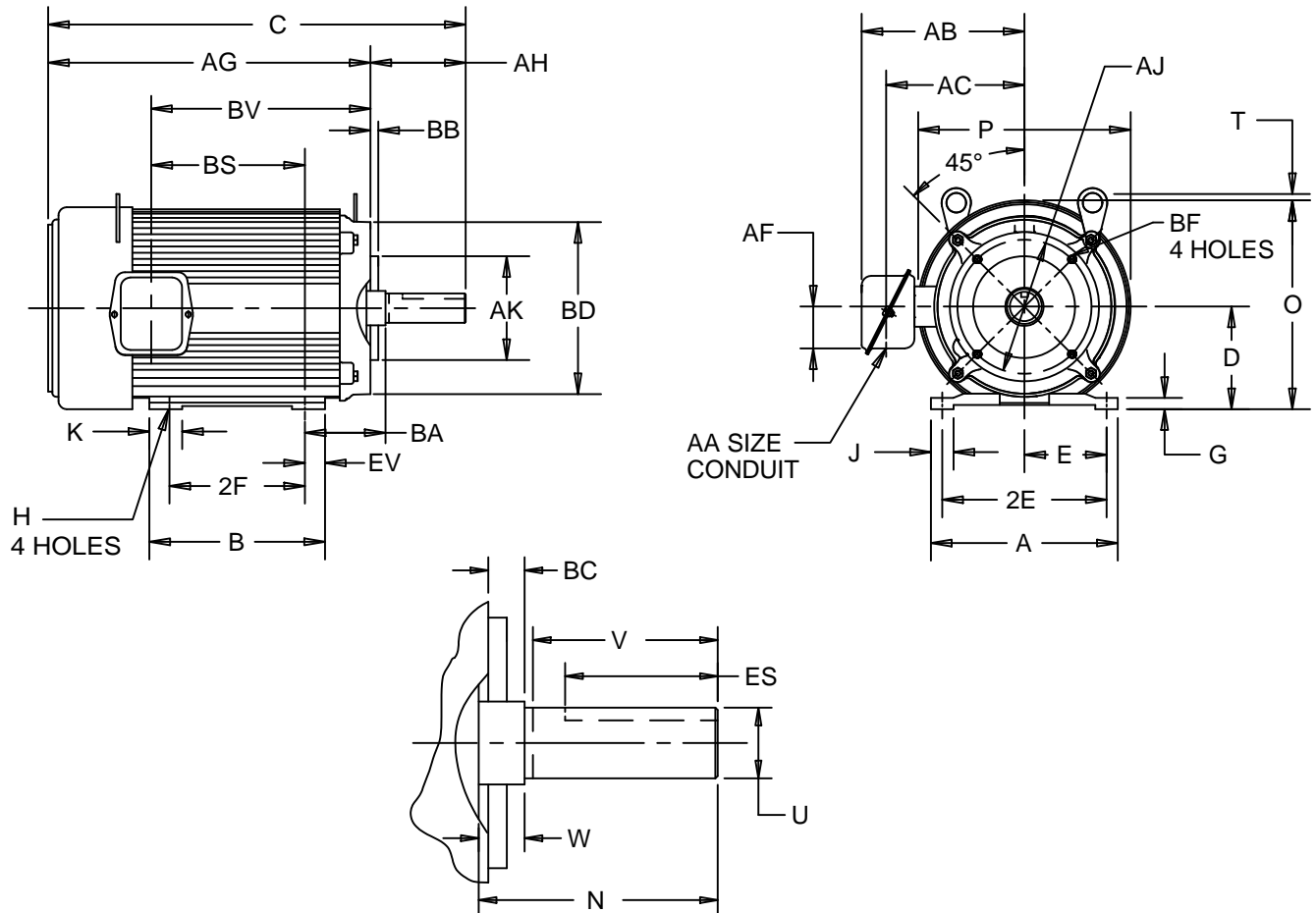

ALL DIMENSIONS ARE IN INCHES AND MILLIMETERS

UNITS	A	B	C	D -.06	E	2E ±.03	G	H +.05	J	K	N	O	P ²	T	U -.0005
IN	8.38	6.38	16.19	4.50	3.75	7.50	.38	.41	.88	1.88	2.88	9.28	9.56	.38	1.1250
MM	213	162	411	143	95	191	10	10	22	48	73	236	243	10	25.575

UNITS	V MIN	W	AA	AB	AC	AF	AG	AH	AJ	AK -.003	BA	BB -.06	BC	BD
IN	2.56	.13	.750	7.50	6.31	2.13	13.56	2.63	5.875	4.500	3.50	.19	.13	6.50
MM	65	3		191	160	54	344	67	149.23	114.30	89	5	3	165

UNITS	BF ⁷	BS	BV	ES MIN	EV	SQ KEY
IN	3/8-16 X .56	4.78	8.38	1.78	.44	.250
MM		121	213	45	11	6.35

FRAME	UNITS	2F ±.03
182TCH	IN	4.50
	MM	114
184TCH	IN	5.50
	MM	140

TOLERANCES	
FACE RUNOUT	.004 T.I.R.
PERMISSIBLE ECCENTRICITY OF MOUNTING RABBET	.004 T.I.R.
PERMISSIBLE SHAFT RUNOUT	.002 T.I.R.

- 1: ALL ROUGH CASTING DIMENSIONS MAY VARY BY .25" DUE TO CASTING AND/OR FABRICATION VARIATIONS.
- 2: LARGEST MOTOR WIDTH.
- 3: FRAME REFERENCE: 8.250"/182/184

- 4: CONDUIT BOX MAY BE LOCATED ON EITHER SIDE OF MOTOR. CONDUIT OPENINGS MAY BE LOCATED IN STEPS OF 90 DEGREES REGARDLESS OF LOCATION. STANDARD AS SHOWN WITH CONDUIT OPENING DOWN.
- 5: TOLERANCES SHOWN ARE IN INCHES ONLY.
- 6: ALL TAPPED HOLES ARE UNIFIED NATIONAL COARSE, RIGHT HAND THREAD.
- 7: TAP SIZE AND BOLT PENETRATION ALLOWANCE.

07-2871/B

Nidec Motor Corporation
St. Louis, Missouri

INFORMATION DISCLOSED ON THIS DOCUMENT IS CONSIDERED PROPRIETARY AND SHALL NOT BE REPRODUCED OR DISCLOSED WITHOUT WRITTEN CONSENT OF NIDEC MOTOR CORPORATION



ISSUED BY
R. KING
APPROVED BY
J. HAGENE

IHP_DP_NMCA (MAR-2011) SOLIDEDGE