

EFFECTIVE:
19-SEP-13

SUPERSEDES:
12-MAY-11

DIMENSION PRINT
UNIMOUNT WITH OVERSIZED OUTLET BOX
FRAME: 213- 215T
BASIC TYPE: UT

PRINT:
07-2877-01

SHEET:
1 OF 1

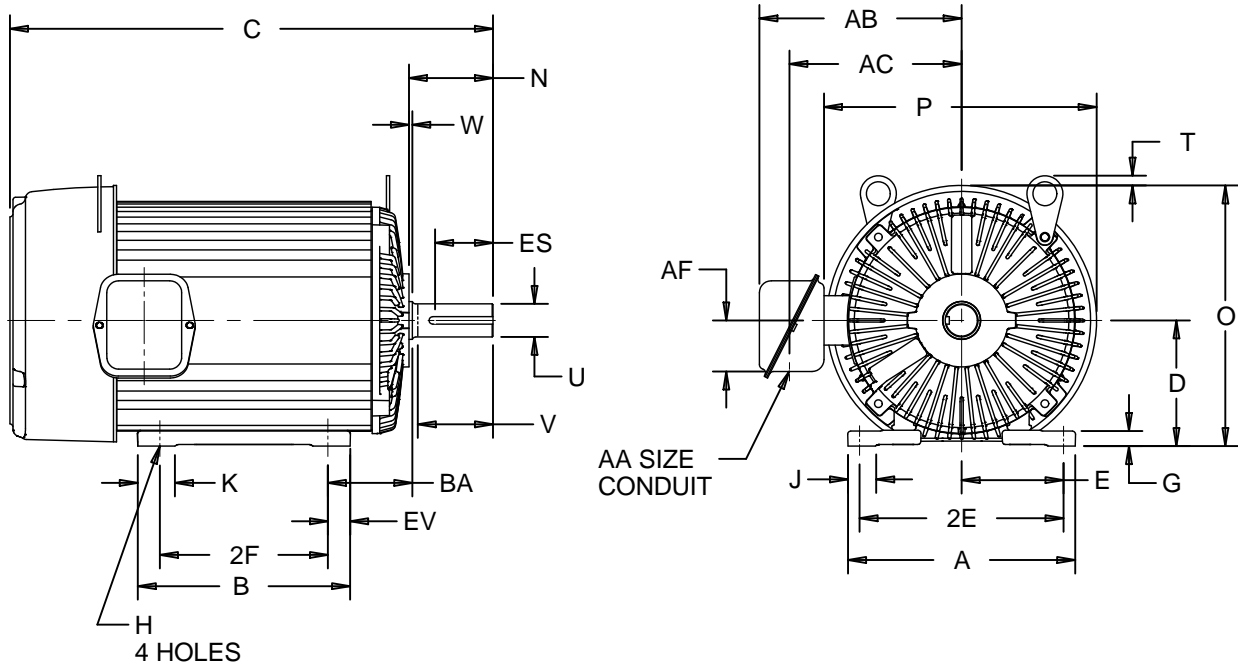

ALL DIMENSIONS ARE IN INCHES AND MILLIMETERS

UNITS	A	D -.06	E	2E ±.03	G	H +.05	J	K	N	O	P ²	T
IN	9.50	5.25	4.25	8.50	.63	.41	1.16	1.56	3.50	10.88	11.25	.41
MM	241	133	108	216	16	10	29	40	89	276	286	10

UNITS	U -.0005	V MIN	W	AA	AB	AC	AF	BA	ES MIN	EV	SQ KEY
IN	1.3750	3.13	.13	1.00	9.00	7.22	2.63	3.50	2.41	.94	.313
MM	34.925	79	3		229	183	67	89	61	24	7.95

FRAME	UNITS	B	C	2F ±.03	BS
213T	IN	7.38	18.63	5.50	6.16
	MM	187	473	140	156
215T	IN	8.88	20.13	7.00	7.66
	MM	225	511	178	194

1: ALL ROUGH CASTING DIMENSIONS MAY VARY BY .25" DUE TO CASTING AND/OR FABRICATION VARIATIONS.
2: LARGEST MOTOR WIDTH.
3: FRAME REFERENCE: 9.500"/213/11.000"/215

4: CONDUIT BOX MAY BE LOCATED ON EITHER SIDE OF MOTOR. CONDUIT OPENINGS MAY BE LOCATED IN STEPS OF 90 DEGREES REGARDLESS OF LOCATION. STANDARD AS SHOWN WITH CONDUIT OPENING DOWN.
5: TOLERANCES SHOWN ARE IN INCHES ONLY.

07-2877/C

Nidec Motor Corporation
St. Louis, Missouri

INFORMATION DISCLOSED ON THIS DOCUMENT IS CONSIDERED PROPRIETARY AND SHALL NOT BE REPRODUCED OR DISCLOSED WITHOUT WRITTEN CONSENT OF NIDEC MOTOR CORPORATION



ISSUED BY
R. KING
APPROVED BY
J. O'BRIEN

IHP_DP_NMCA (MAR-2011) SOLIDEDGE