

EFFECTIVE:
12-FEB-20

SUPERSEDES:
NEW

DIMENSION PRINT

STEEL EDGE C-FACE WITH OVERSIZE CONDUIT BOX AND CANOPY CAP

FRAME: 254, 256TC
BASIC TYPE: SEF

PRINT:
07-3429-01

SHEET:
1 OF 1

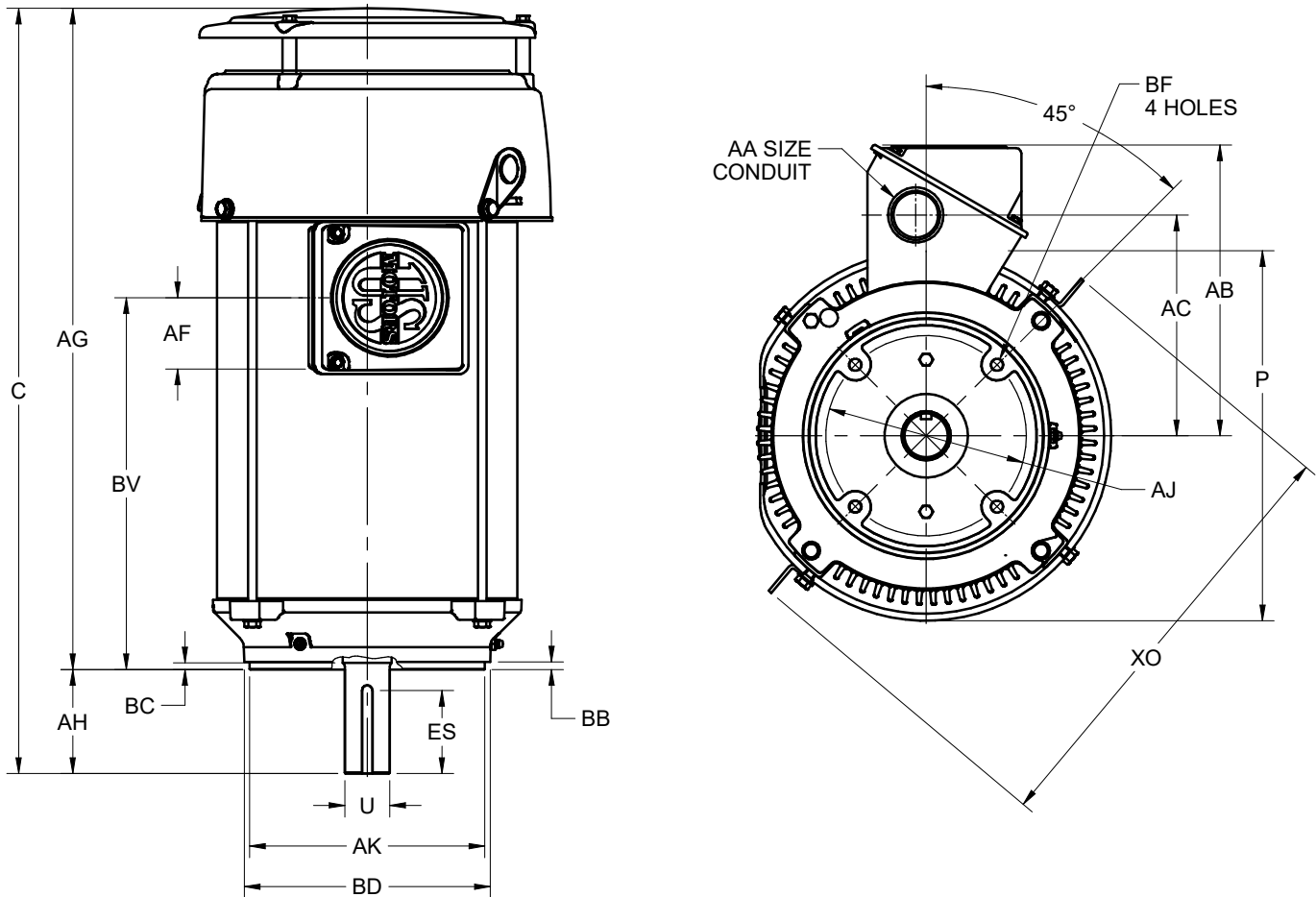

ALL DIMENSIONS ARE IN INCHES AND MILLIMETERS

UNITS	C	P ²	U _{-.001}	AA ⁵	AB	AC	AF	AG	AH	AJ	AK _{-.003}	BB _{MIN}	BC
IN	27.66	13.38	1.625	1.50	10.53	8.00	2.59	23.94	3.75	7.250	8.500	.25	.25
MM	703	340	41.28		267	203	66	608	95	184.15	215.90	6	6

UNITS	BD	BF ^{3,4}	BV	XO	ES _{MIN}	SQ KEY
IN	9.00	1/2-13 X .75	13.44	15.94	2.91	.375
MM	229		341	405	74	9.53

TOLERANCES

FACE RUNOUT	.004 TIR
PERMISSIBLE ECCENTRICITY OF MOUNTING RABBET	.004 TIR
PERMISSIBLE SHAFT RUNOUT	.002 TIR

1. DIMENSIONS MAY VARY .25" DUE TO CASTING AND/OR FABRICATION VARIATIONS
2. LARGEST MOTOR WIDTH
3. ALL TAP HOLES ARE UNIFIED NATIONAL COARSE, RIGHT HAND THREAD
4. TAP SIZE AND BOLT PENETRATION ALLOWANCE
5. BASIC CONDUIT FITTING SIZE. CONDUIT OPENING ON THE SIDE OF THE CONDUIT BOX WILL ACCEPT 1-1/2 NPT CONDUIT FITTING
6. CONDUIT OPENING(S) MAY BE LOCATED IN STEPS OF 180° REGARDLESS OF LOCATION. STANDARD LOCATION IS SHOWN WITH CONDUIT OPENING DOWN
7. TOLERANCES ARE SHOWN IN INCHES ONLY
8. FRAME REFERENCE: 13.000/254//256

07-3429-01/-

Nidec Motor Corporation
St. Louis, Missouri

INFORMATION DISCLOSED ON THIS DOCUMENT
IS CONSIDERED PROPRIETARY AND SHALL NOT BE
REPRODUCED OR DISCLOSED WITHOUT WRITTEN
CONSENT OF NIDEC MOTOR CORPORATION



ISSUED BY
R. TIMMERMANN
APPROVED BY
P. HOGG

IHP_DP_NMCA (MAR-2011) SOLIDEDGE