

EFFECTIVE:
16-JAN-17

SUPERSEDES:
NEW

DIMENSION PRINT
WORLD MOTOR INVERTER DUTY
FRAME: 254T, 256T
BASIC TYPE: CTI

PRINT:
08-1014

SHEET:
1 OF 1

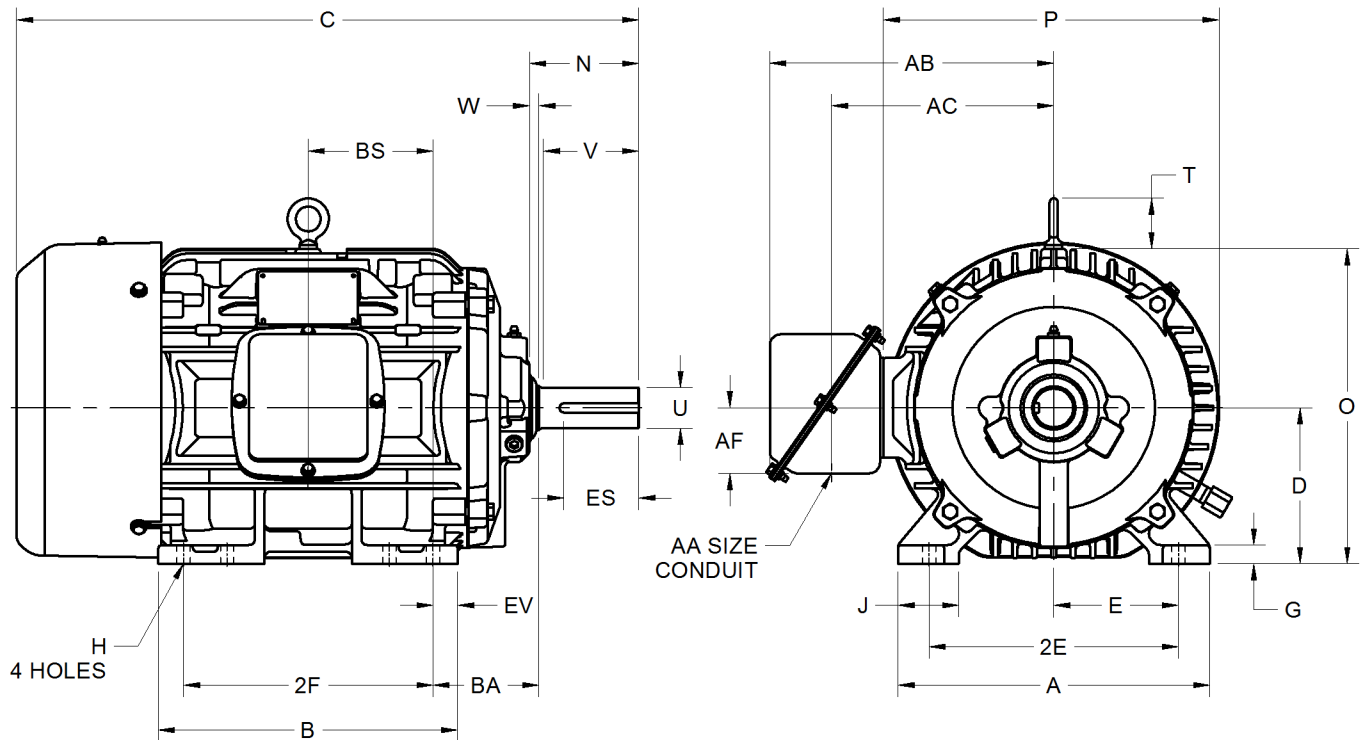

ALL DIMENSIONS ARE IN INCHES AND MILLIMETERS

UNITS	A	B	C	D -.06	E	2E ±.03	G	H +.05	J	K	N	O	P ²
IN	12.50	12.00	24.94	6.25	5.00	10.00	.75	.53	2.44	4.25	4.38	12.63	13.47
MM	318	305	633	159	127	254	19	13	62	108	111	320	342

UNITS	T	U -.001	V MIN	W	AA	AB	AC	AF	BA	BS	EV	ES MIN	SQ KEY
IN	2.03	1.625	3.75	.38	1.25	11.38	8.91	2.63	4.25	5.00	1.00	2.91	.375
MM	52	41.28	95	10		289	226	67	108	127	25	74	9.53

FRAME	UNITS	2F ±.03
254T	IN	8.25
	MM	210
256T	IN	10.00
	MM	254

1. DIMENSIONS MAY VARY .25" DUE TO CASTING AND/OR FABRICATION VARIATIONS
2. LARGEST MOTOR WIDTH
3. STANDARD ASSEMBLY POSITION F-1 IS SHOWN. F-2 IS PROVIDED WHEN SPECIFIED. CONDUIT OPENING MAY BE LOCATED IN STEPS OF 90° REGARDLESS OF THE LOCATION
4. TOLERANCES ARE SHOWN IN INCHES ONLY

08-1014/-

Nidec Motor Corporation
St. Louis, Missouri

INFORMATION DISCLOSED ON THIS DOCUMENT IS CONSIDERED PROPRIETARY AND SHALL NOT BE REPRODUCED OR DISCLOSED WITHOUT WRITTEN CONSENT OF NIDEC MOTOR CORPORATION



ISSUED BY
R. TIMMERMANN
APPROVED BY
M. CULLEN

IHP_DP_NMCA (MAR-2011) SOLIDEDGE