

EFFECTIVE:  
**05-SEP-19**

SUPERSEDES:  
**12-JUL-19**

**DIMENSION PRINT**  
WORLD MOTOR CORRODUTY WITH SHROUD

FRAME: 447TS  
BASIC TYPE: TC

PRINT:  
**08-1077-01**

SHEET:  
**1 OF 1**

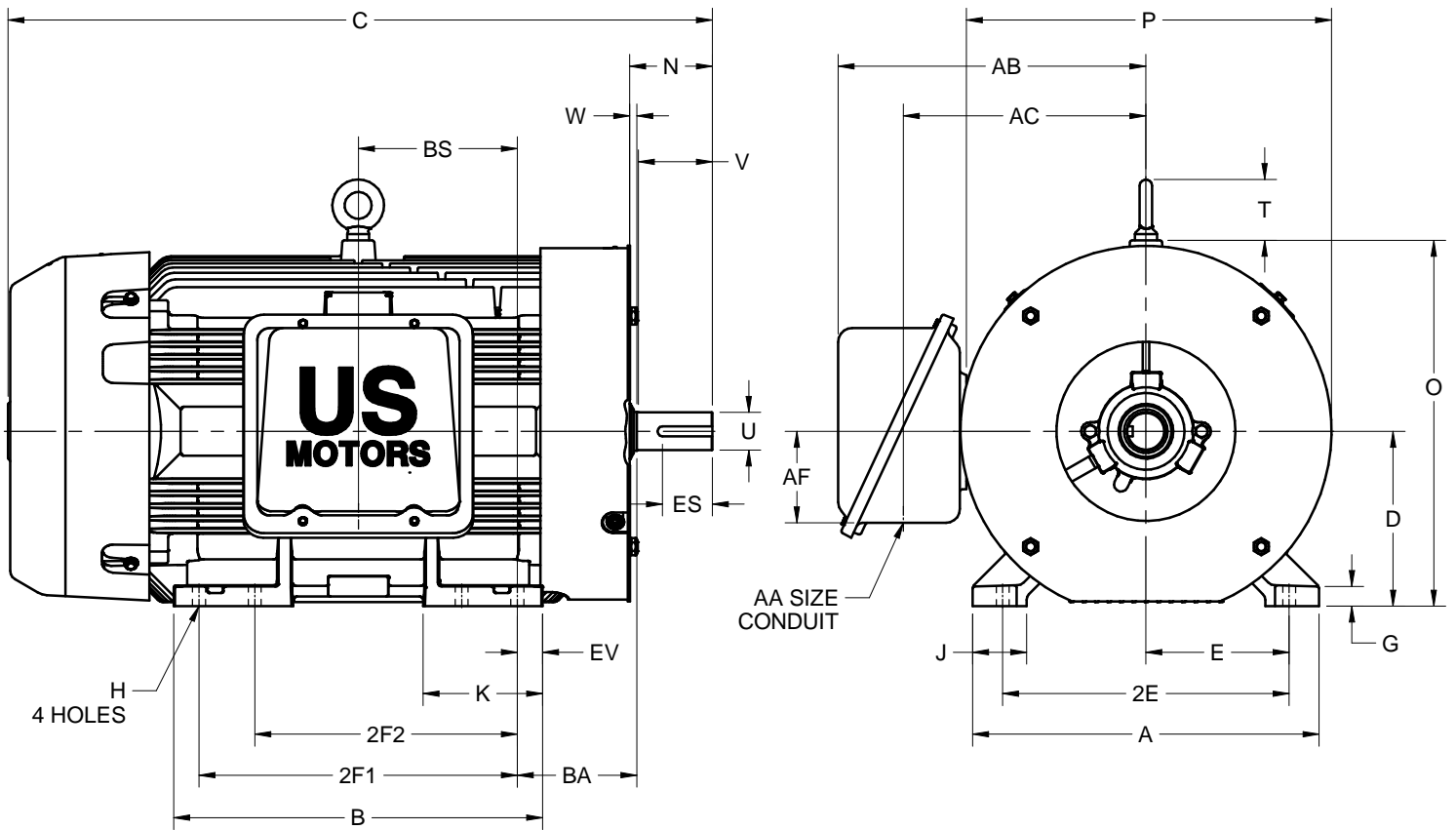

ALL DIMENSIONS ARE IN INCHES AND MILLIMETERS

UNITS	A	B	C	D -.06	E	2E ±.03	2F1 ±.03	2F2 ±.03	G	H +.05	J	K	N
IN	21.75	23.19	44.25	11.00	9.00	18.00	20.00	16.50	1.25	.81	3.38	7.50	5.19
MM	552	589	1124	279	229	457	508	419	32	21	86	191	132

UNITS	O	P <sup>2</sup>	T	U -.001	V MIN	W	AA	AB	AC	AF	BA	BS	EV
IN	23.00	22.81	3.81	2.375	4.50	.44	3 NPT	19.34	15.25	5.75	7.50	10.00	1.59
MM	584	579	97	60.33	114	11		491	387	146	191	254	40

UNITS	ES MIN	SQ KEY
IN	3.03	.625
MM	77	15.88

1. DIMENSIONS MAY VARY .25" DUE TO CASTING AND/OR FABRICATION VARIATIONS
2. LARGEST MOTOR WIDTH
3. STANDARD ASSEMBLY POSITION F-1 IS SHOWN. F-2 IS PROVIDED WHEN SPECIFIED. CONDUIT OPENING MAY BE LOCATED IN STEPS OF 90° REGARDLESS OF THE LOCATION
4. TOLERANCES ARE SHOWN IN INCHES ONLY

08-1077-01/B

**Nidec Motor Corporation**  
St. Louis, Missouri

INFORMATION DISCLOSED ON THIS DOCUMENT IS CONSIDERED PROPRIETARY AND SHALL NOT BE REPRODUCED OR DISCLOSED WITHOUT WRITTEN CONSENT OF NIDEC MOTOR CORPORATION



ISSUED BY  
**R. TIMMERMANN**  
APPROVED BY  
**K. POTTER**

IHP\_DP\_NMCA (MAR-2011) SOLIDEDGE