

EFFECTIVE:  
**03-OCT-19**

**DIMENSION PRINT**  
WEATHER PROTECTED TYPE II  
FRAME: 449TPH, TP, TPA  
BASIC TYPE: RU

PRINT:  
**09-3365**

SUPERSEDES:  
**30-OCT-18**

SHEET:  
**1 OF 1**

PUMP SHAFT, ADJUSTING NUT AND LOCKING SCREWS ARE NOT FURNISHED WITH MOTOR

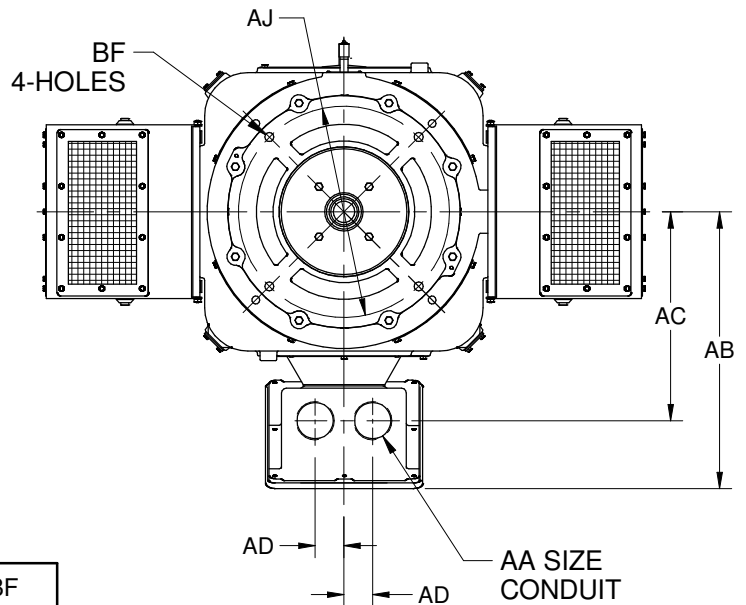
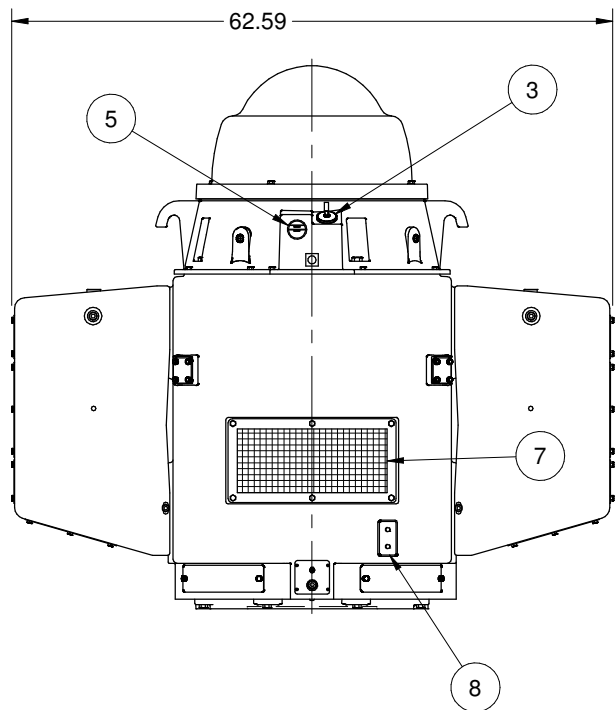
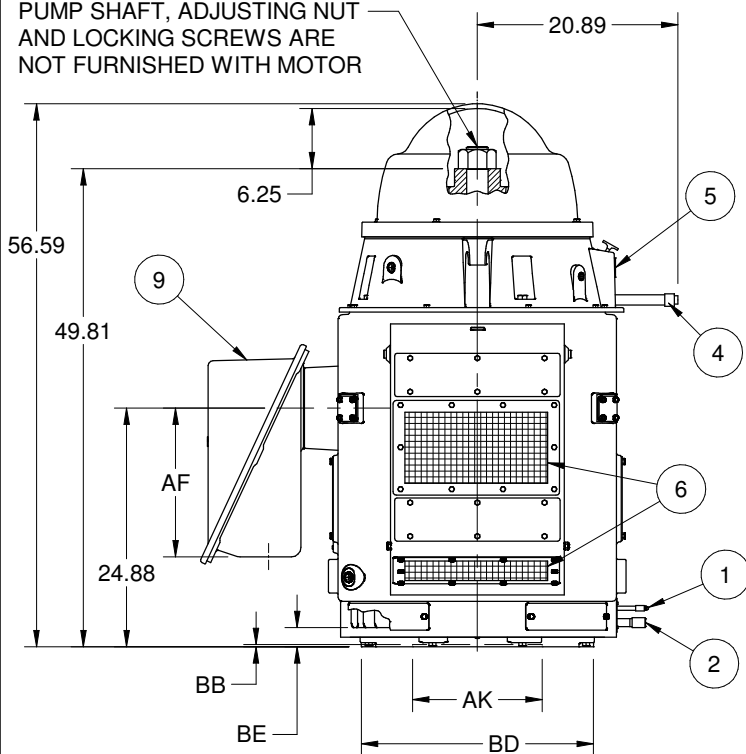

| AA        |
|-----------|
| 2 NPT     |
| 2 1/2 NPT |
| 3 NPT     |
| 3 1/2 NPT |
| 4 NPT     |

| C/BOX VOLUME (CU. IN.) | QTY OF CONDUIT HOLES | AB    | AC    | AD   | AF    |
|------------------------|----------------------|-------|-------|------|-------|
| 2000                   | 2                    | 28.84 | 21.75 | 3.00 | 15.50 |
| 3400                   | 2                    | 33.44 | 21.75 | 3.00 | 15.50 |

| FRAME  | AJ    | AK +.005 | BB MIN | BD MAX | BE   | BF   |
|--------|-------|----------|--------|--------|------|------|
| 449PH  | 14.75 | 13.500   | .25    | 20.00  | 2.00 | .688 |
| ⑩ 449P | 14.75 | 13.500   |        | 24.50  |      | .688 |
|        | 22.00 |          | 30.50  | .938   |      |      |
| 449PA  | 26.00 | 22.000   |        |        |      | .813 |

FEATURE LISTING

|                           |                              |
|---------------------------|------------------------------|
| 1 LOWER GREASE FILL       | 6 AIR INTAKE, 180° APART     |
| 2 LOWER GREASE DRAIN      | 7 AIR EXHAUST, 180° APART    |
| 3 UPPER SUMP OIL FILL     | 8 GRD PADS, DIAG OPP, 1/2-13 |
| 4 UPPER SUMP OIL DRAIN    | 9 MAIN CONDUIT BOX           |
| 5 UPPER SUMP SIGHT WINDOW | 10 449P HAS TWO BOLT CIRCLES |

ALL DIMENSIONS ARE IN INCHES.

| TOLERANCES                                  |          |
|---|----------|
| FACE RUNOUT                                 | .007 TIR |
| PERMISSIBLE ECCENTRICITY OF MOUNTING RABBET | .007 TIR |
| NON-MACHINED DIMENSIONS MAY VARY BY ±.25    |          |

09-3365/A

**Nidec Motor Corporation**  
St. Louis, Missouri

INFORMATION DISCLOSED ON THIS DOCUMENT IS CONSIDERED PROPRIETARY AND SHALL NOT BE REPRODUCED OR DISCLOSED WITHOUT WRITTEN CONSENT OF NIDEC MOTOR CORPORATION



ISSUED BY  
**R. KING**  
APPROVED BY  
**T. COLOMA**

IHP\_DP\_NMCA (MAR-2011) SOLIDEDGE