

EFFECTIVE:
16-SEP-19

DIMENSION PRINT
WEATHER PROTECTED TYPE I
 FRAME: H444, H445TP, TPA
 BASIC TYPE: RU

PRINT:
09-3403

SUPERSEDES:
10-SEP-19

SHEET:
1 OF 1

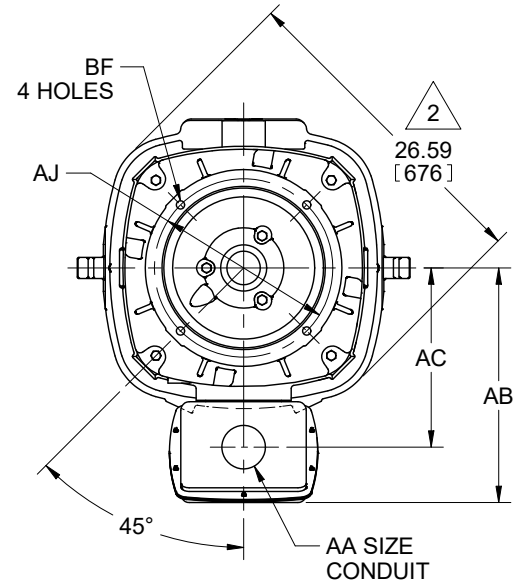
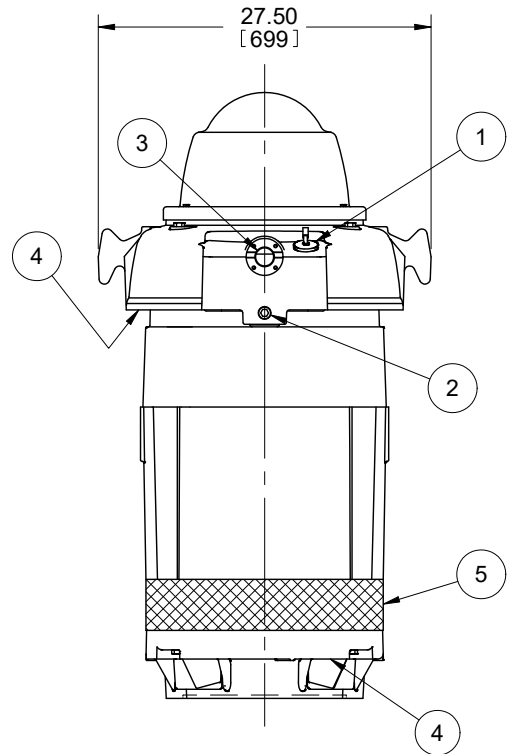
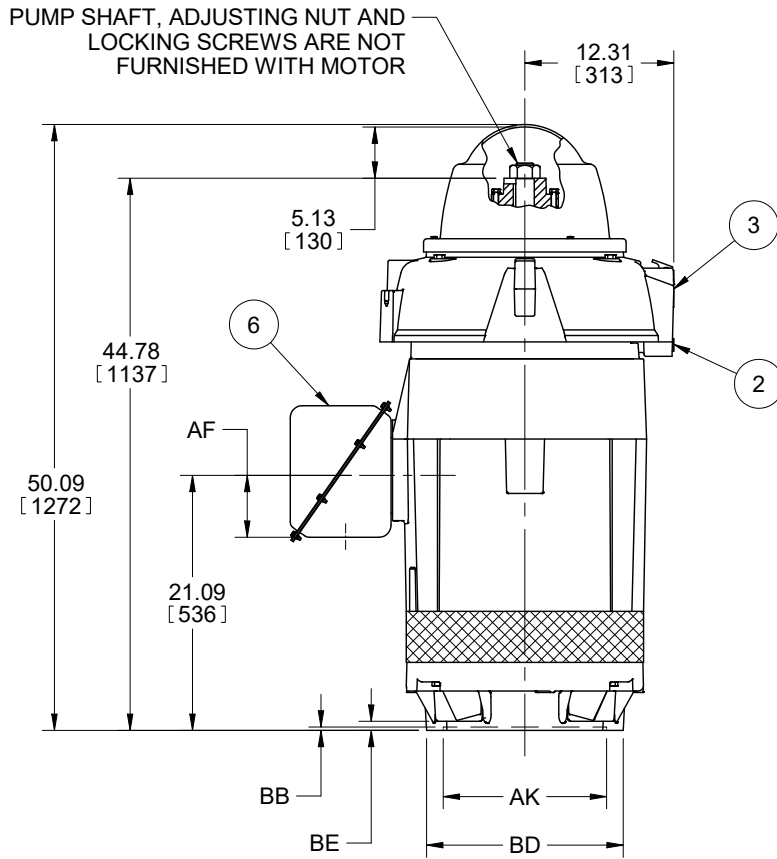

FRAME	UNITS	BD MAX
H444, H445TP	IN	16.50
	MM	419
H444, H445TPA	IN	20.00
	MM	508

UNITS	C/BOX VOLUME (CU. IN.)	AA	AB	AC	AF
IN	860	3.00	19.38	14.81	5.13
MM			492	376	130

UNITS	AJ	AK +.005	BB MIN	BE	BF
IN	14.750	13.500	.25	.75	.688
MM	374.65	342.9	6	19	17.48

1. CONDUIT OPENING MAY BE LOACED IN STEPS OF 90 DEGREES. STANDARD AS SHOWN WITH CONDUIT OPENING DOWN.

2. LARGEST MOTOR WIDTH.

ALL DIMENSIONS ARE IN INCHES AND MILLIMETERS (TOLERANCES ARE IN INCHES)

FEATURE LISTING

NO.	DESCRIPTION	NO.	DESCRIPTION
1	UPPER SUMP OIL FILL	6	MAIN CONDUIT BOX
2	UPPER SUMP OIL DRAIN		
3	UPPER SUMP SIGHT WINDOW		
4	AIR INTAKE		
5	AIR EXHAUST, 360° AROUND		

TOLERANCES	
FACE RUNOUT	.007 TIR
PERMISSIBLE ECCENTRICITY OF MOUNTING RABBET	.007 TIR
MAXIMUM SHAFT END PLAY	.010
NON-MACHINED DIMENSIONS MAY VARY BY ±.25	

09-3403/A

Nidec Motor Corporation
 St. Louis, Missouri

INFORMATION DISCLOSED ON THIS DOCUMENT IS CONSIDERED PROPRIETARY AND SHALL NOT BE REPRODUCED OR DISCLOSED WITHOUT WRITTEN CONSENT OF NIDEC MOTOR CORPORATION



ISSUED BY
K. FRIEDMAN
 APPROVED BY
T. COLOMA

IHP_DP_NMCA (MAR-2011) SOLIDEDGE