

VAR	MODEL	CUSTOMER	CAT. NO.	A	B	C	D	HP	VOLTS	SF	AMPS	HZ	RPM	CONN VOLTS	PROT.	DESCRIPTION / REMARKS
001	T55JXCPV-1527	USEM	D13CPA2P9	10.31	-----	-----	-----	1/3	115/230	1.35	3.8/1.9	60	1725	-----	AUTO	N56 ODP
002	T55JXCSC-1554	USEM	D13CPM2PH9	10.31	-----	-----	-----	1/3	115/230	1.35	3.8/1.9	60	1725	-----	MAN.	N56 ODP

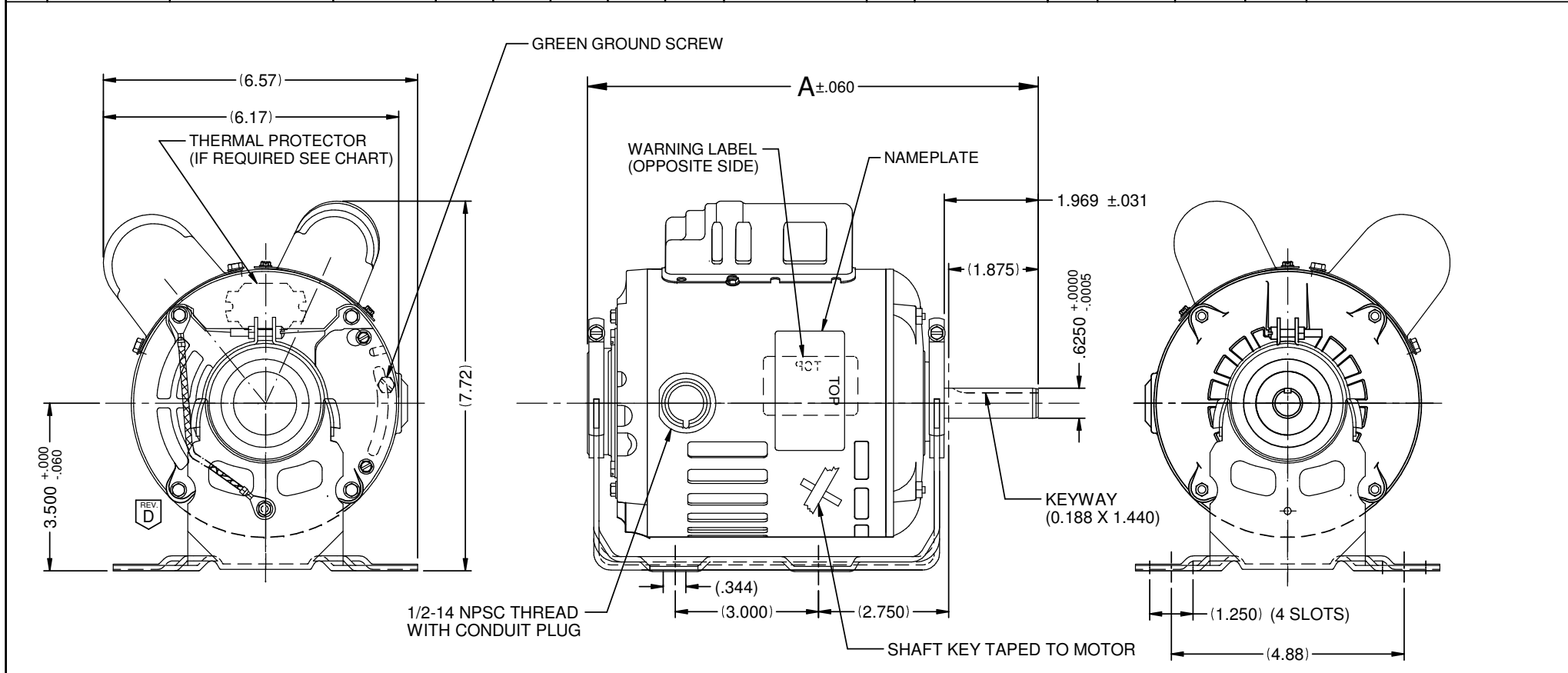

NIDEC MOTOR CORPORATION 25-Oct-17 MOTOR IS CCW LEAD END, TO REVERSE ROTATION INTERCHANGE RED AND BLACK LEADS REFER TO S.E.I.M. 24-1

REVISION RECORD FOR: ECO E29755 CHANGE DRAWING TO SHOW THAT THE GROUND WIRE IS ROUTED FROM INSIDE THE BASE		TOLERANCES ON DIMENSIONS (UNLESS OTHERWISE SPECIFIED)		NIDEC MOTOR CORPORATION				INFORMATION DISCLOSED ON THIS DOCUMENT IS CONSIDERED PROPRIETARY AND SHALL NOT BE REPRODUCED OR DISCLOSED WITHOUT WRITTEN CONSENT OF NIDEC MOTOR CORPORATION		REVISION DATE: 26-OCT-17	
ISSUED BY: J. ALVARADO		ENGINEER APPROVED: R. CRUZ		CUSTOMER DETAIL DRAWING				CODE: V02		ITEM NO.: 803952	
V02_NMCB (MAR-2014)		ANGLES X° = ±1°		TITLE: CUSTOMER DETAIL DRAWING				REV: D		SHEET NUMBER: 1 OF 4 DWG SIZE: B	