

VAR	MODEL	CUSTOMER	H.P.	VOLTS	AMPS	SW. VER.	HZ	R.P.M.	ROTATION	MODE	CUST. PT. NO.	DIM. A	DIM. B	DIM. C
001	M55PWABT-1149	WHOLESALE HAC	1/2-1/3	115/208-230	6.4/4.0-3.8 & 6.4/4.0-3.8	46	60&50	1250/ VAR	CW LE REV	TORQUE	B8630UI	4.787	11.350	2.063
002	M55PWABU-1150	WHOLESALE HAC	1-3/4	115/208-230	12.1/7.6-7.1 & 12.1/7.6-7.1	46	60&50	1250/ VAR	CW LE REV	TORQUE	B8650UI	4.787	11.850	2.563
003	M55PWABV-1151	WHOLESALE HAC	1/2-1/3	115/208-230	6.8/4.2-4.1 & 6.8/4.1-4.1	46	60&50	1800/ VAR	CW LE REV	TORQUE	B8430UI	4.787	11.350	2.063
004	M55PWABW-1152	WHOLESALE HAC	1-3/4	115/208-230	11.1/6.7-6.6 & 10.9/6.6-6.7	46	60&50	1800/ VAR	CW LE REV	TORQUE	B8450UI	4.787	11.850	2.563

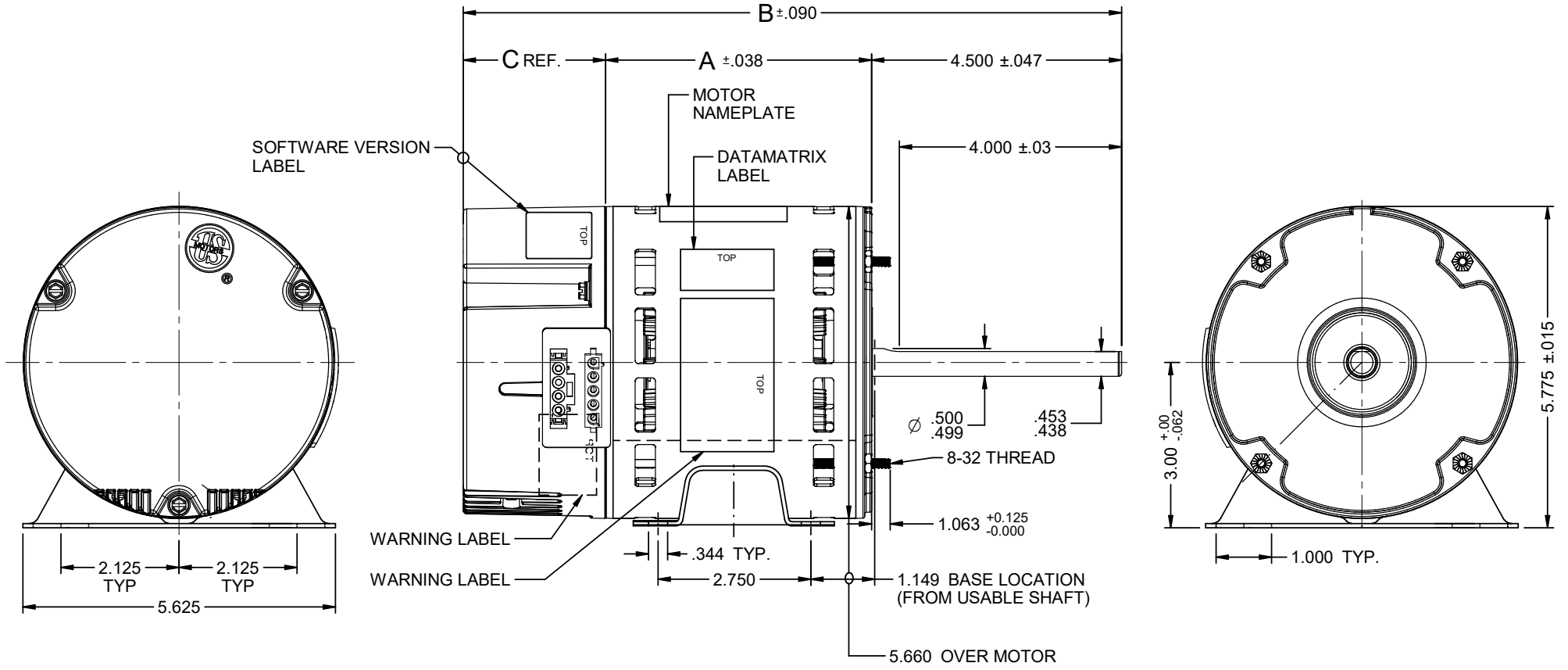

NIDEC MOTOR CORPORATION 06-Dec-21

REFER TO S.E.I.M. 24-1

REVISION RECORD FOR: E41234	
ADDED CRITICAL REQUIREMENT #5	
ISSUED BY: R. PEREZ	ENGINEER APPROVED: M. DE LEON

TOLERANCES ON DIMENSIONS (UNLESS OTHERWISE SPECIFIED)	
INCHES .XX = ± .010 .XXX = ± .005	mm
ANGLES X° = ± 1°	

NIDEC MOTOR CORPORATION			
INFORMATION DISCLOSED ON THIS DOCUMENT IS CONSIDERED PROPRIETARY AND SHALL NOT BE REPRODUCED OR DISCLOSED WITHOUT WRITTEN CONSENT OF NIDEC MOTOR CORPORATION			
TITLE		CODE	REVISION DATE:
CUSTOMER DETAIL DRAWING		V02	06-DEC-21
ITEM NO.	REV	SHEET NUMBER	DWG SIZE
835661	D	1 OF 6	B

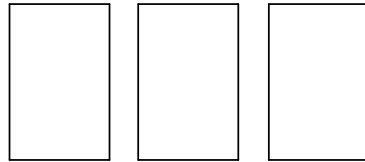
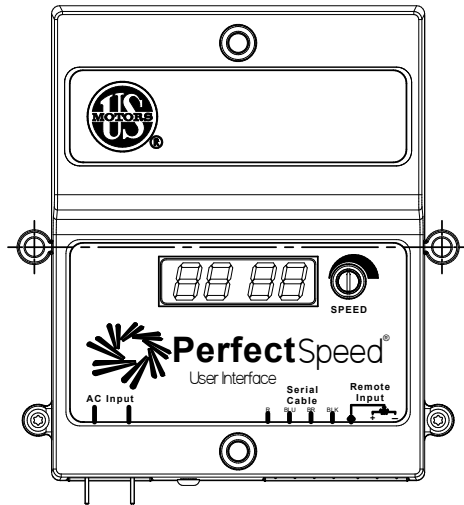

DOUBLE SIDE FOAM TAPE (3) PIECES

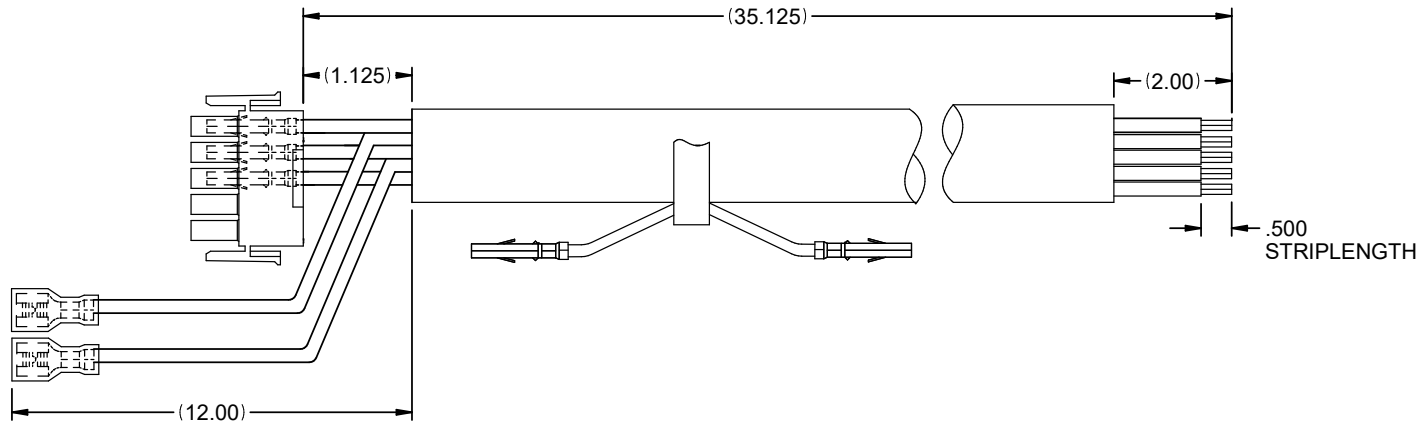
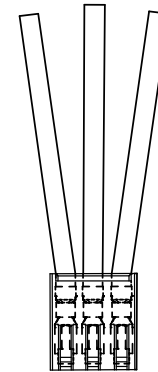
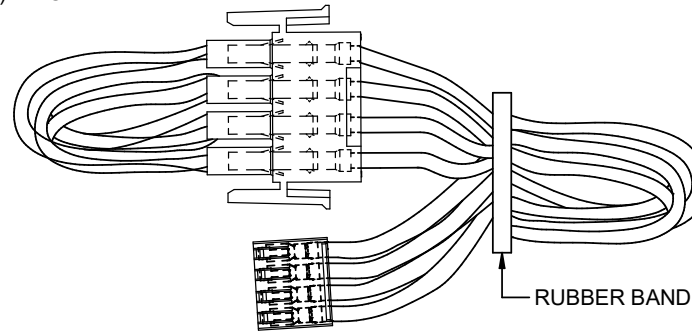
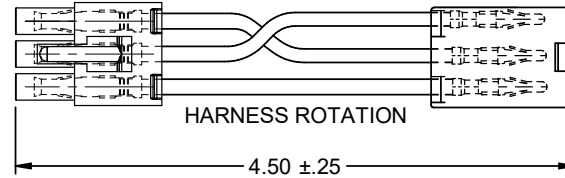

NIDEC MOTOR CORPORATION 06-Dec-21

REFER TO S.E.I.M. 24-1

REVISION RECORD FOR: E41234	
ADDED CRITICAL REQUIREMENT #5	
ISSUED BY: R. PEREZ	ENGINEER APPROVED: M. DE LEON

TOLERANCES ON DIMENSIONS (UNLESS OTHERWISE SPECIFIED)	
INCHES .XX = ± .010 .XXX = ± .005	mm
ANGLES X° = ±1°	

NIDEC MOTOR CORPORATION			
DESCRIPTION: M55 BALL BRG, OPEN, THRU BOLT, VARIABLE SPEED			REVISION DATE: 06-DEC-21
TITLE: CUSTOMER DETAIL DRAWING	CODE: V02	ITEM NO.: 835661	REV: D
		SHEET NUMBER: 5 OF 6	DWG SIZE: B